

IRRIGATION AUTHORITY



Procurement for Supply of Spare Parts

Procurement Reference No: OMD/ SPAREPARTS/07/23

*IRRIGATION AUTHORITY
5th Floor, Fon Sing Building
12, Edith Cavell Street
Port-Louis
Tel No: 210 6596
Fax No: 212 7652
Email : irrig@irrig.org*

14 April 23

Table of Contents

PART 1 – Bidding Procedures.....	1
Section I. Instructions to Bidders.....	2
Section II. Bidding Data Sheet (BDS).....	27
Section III. Evaluation and Qualification Criteria.....	33
Section IV. Bidding Forms.....	38
PART 2 – Supply Requirements.....	54
Section V. Schedule of Requirements.....	55
PART 3 - Contract.....	61
Section VI. General Conditions of Contract.....	62
Section VII. Special Conditions of Contract.....	63
Section VIII. Contract Forms.....	67
1. Contract Agreement.....	68
2. Performance Security.....	70
3. Bank/Insurance Guarantee for Advance Payment.....	72

PART 1 – Bidding Procedures

Section I. Instructions to Bidders

Table of Clauses

A. General.....	4
1. Scope of Bid.....	4
2. Source of Funds	4
3. Public Entities Related to Bidding Documents and to Challenge and Appeal	4
4. Fraud and Corruption.....	5
5. Eligible Bidders	7
6. Eligible Goods and Related Services.....	9
B. Contents of Bidding Documents	9
7. Sections of Bidding Documents.....	9
8. Clarification of Bidding Documents	10
9. Amendment of Bidding Documents	10
C. Preparation of Bids	10
10. Cost of Bidding	10
11. Language of Bid.....	10
12. Documents Comprising the Bid.....	11
13. Bid Submission Form and Price Schedules	11
14. Alternative Bids	11
15. Bid Prices and Discounts	11
16. Currencies of Bid	13
17. Documents Establishing the Eligibility of the Bidder	13
18. Documents Establishing the Eligibility of the Goods and Related Services	14
19. Documents Establishing the Conformity of the Goods and Related Services.....	14
20. Documents Establishing the Qualifications of the Bidder	14
21. Period of Validity of Bids.....	15
22. Bid Security	15
23. Format and Signing of Bid.....	17
D. Submission and Opening of Bids.....	17
24. Submission, Sealing and Marking of Bids.....	17
25. Deadline for Submission of Bids	18
26. Late Bids	18
27. Withdrawal, Substitution, and Modification of Bids	18
28. Bid Opening.....	19
E. Evaluation and Comparison of Bids	20
29. Confidentiality	20

30.	Clarification of Bids.....	20
31.	Responsiveness of Bids.....	20
32.	Nonconformities, Errors, and Omissions.....	21
33.	Preliminary Examination of Bids.....	22
34.	Examination of Terms and Conditions; Technical Evaluation.....	22
35.	Conversion to Single Currency.....	22
36.	Margin of Preference	22
37.	Evaluation of Bids.....	22
38.	Comparison of Bids	24
39.	Post-qualification of the Bidder	24
40.	Purchaser’s Right to Accept Any Bid, and to Reject Any or All Bids	24
F. Award of Contract		24
41.	Award Criteria	24
42.	Purchaser’s Right to Vary Quantities at Time of Award.....	24
43.	Notification of Award.....	25
44.	Signing of Contract.....	25
45.	Performance Security.....	25
46.	Debriefing.....	26

Section I. Instructions to Bidders

A. General

1. **Scope of Bid**
 - 1.1 The Purchaser **indicated in the Bidding Data Sheet (BDS)**, issues these Bidding Documents for the supply of Goods and Related Services incidental thereto as specified in Section V, Schedule of Requirements. The name and identification number of this procurement through Open Advertised Bidding (open for local and overseas suppliers) are **specified in the BDS**. The name, identification, and number of lots are **provided in the BDS**.
 - 1.2 Throughout these Bidding Documents:
 - (a) the term “in writing” means communicated in written form (e.g. by mail, e-mail, fax,) with proof of receipt;
 - (b) if the context so requires, “singular” means “plural” and vice versa; and
 - (c) “day” means calendar day.
2. **Source of Funds**
 - 2.1 Unless otherwise stated in the **BDS**, this procurement shall be financed by the Public Body’s own budgetary allocation.
3. **Public Entities Related to Bidding Documents and to Challenge and Appeal**
 - 3.1 The public entities related to these bidding documents are the Public Body, acting as procurement entity (Purchaser), the Procurement Policy Office, in charge of issuing standard bidding documents and responsible for any amendment these may require, the Central Procurement Board in charge of vetting Bidding document, receiving and evaluation of bids in respect of major contracts and the Independent Review Panel, set up under the Public Procurement Act 2006 (hereinafter referred to as the Act.)
 - 3.2 Sections 43, 44 and 45 of the Act provide for challenge and review mechanism. Unsatisfied bidders shall follow procedures prescribed in Regulations 48, 49 and 50 of the Public Procurement Regulations 2008 to challenge procurement proceedings and award of procurement contracts or to file application for review at the Independent Review Panel.
 - 3.3 Challenges and Applications for Review shall be forwarded to the addresses indicated **in the BDS**;

4. Fraud and Corruption

4.1 It is the policy of the Government of the Republic of Mauritius to require Public Bodies, as well as bidders, suppliers, and contractors and their agents (whether declared or not), personnel, subcontractors, sub-consultants, service providers and suppliers, observe the highest standard of ethics during the procurement and execution of contracts. ¹ In pursuance of this policy, the Government of the Republic of Mauritius:

(a) defines, for the purposes of this provision, the terms set forth below as follows:

- (i) “corrupt practice” is the offering, giving, receiving or soliciting, directly or indirectly, of anything of value to influence improperly the actions of another party²;
- (ii) “fraudulent practice” is any act or omission, including a misrepresentation, that knowingly or recklessly misleads, or attempts to mislead, a party to obtain a financial or other benefit or to avoid an obligation;³
- (iii) “collusive practice” is an arrangement between two or more parties⁴ designed to achieve an improper purpose, including to influence improperly the actions of another party;
- (iv) “coercive practice” is impairing or harming, or threatening to impair or harm, directly or indirectly, any party⁵ or the property of the party to influence improperly the actions of a party;
- (v) “obstructive practice” is
 - (aa) deliberately destroying, falsifying, altering or concealing of evidence material to the investigation or making false statements to investigators in order to materially impede the Purchaser’s investigation into allegations of a

¹ In this context, any action taken by a bidder, supplier, contractor, or any of its personnel, agents, sub-consultants, sub-contractors, service providers, suppliers and/or their employees to influence the procurement process or contract execution for undue advantage is improper.

² “Another party” refers to a public official acting in relation to the procurement process or contract execution. In this context, “public official” includes Purchaser’s staff and employees of other organizations taking or reviewing procurement decisions.

³ “Party” refers to a public official; the terms “benefit” and “obligation” relate to the procurement process or contract execution; and the “act or omission” is intended to influence the procurement process or contract execution.

⁴ “Parties” refers to participants in the procurement process (including public officials) attempting to establish bid prices at artificial, noncompetitive levels.

⁵ “Party” refers to a participant in the procurement process or contract execution.

corrupt, fraudulent, coercive or collusive practice; and/or threatening, harassing or intimidating any party to prevent it from disclosing its knowledge of matters relevant to the investigation or from pursuing the investigation, or

- (bb) acts intended to materially impede the exercise of the Purchaser's inspection and audit rights provided for under sub-clause 4.2 below.
 - (b) will reject a proposal for award if it determines that the Bidder recommended for award has, directly or through an agent, engaged in corrupt, fraudulent, collusive, coercive or obstructive practices in competing for the contract in question; and
 - (c) will sanction a firm or an individual, at any time, in accordance with prevailing legislations, including by publicly declaring such firm or individual ineligible, for a stated period of time: (i) to be awarded a public contract; and (ii) to be a nominated^b sub-contractor, consultant, manufacturer or supplier, or service provider of an otherwise eligible firm being awarded a public contract.
- 4.2 In further pursuance of this policy, Bidders shall permit the Purchaser to inspect any accounts and records and other documents relating to the Bid submission and contract performance, and to have them audited by auditors appointed by the Purchaser.
- 4.3 Furthermore, bidders shall be aware of the provision in Clauses 3.1 and 35.1 (a) of the General Conditions of Contract.
- 4.4 Bidders, suppliers and public officials shall also be aware of the provisions stated in sections 51 and 52 of the Public Procurement Act which can be consulted on the website of the Procurement Policy Office (PPO) : ppo.govmu.org
- 4.5 The Purchaser commits itself to take all measures necessary to prevent fraud and corruption and ensures that none of its staff, personally or through his/her close relatives or through a third party, will in connection with the bid for, or the execution of a

^b A nominated sub-contractor, consultant, manufacturer or supplier, or service provider (different names are used depending on the particular bidding document) is one which either has been: (i) included by the bidder in its pre-qualification application or bid because it brings specific and critical experience and know-how that are accounted for in the evaluation of the bidder's pre-qualification application or the bid; or (ii) appointed by the Purchaser.

contract, demand, take a promise for or accept, for him/herself or third person, any material or immaterial benefit which he/she is not legally entitled to. If the Purchaser obtains information on the conduct of any of its employees which is a criminal offence under the relevant Anti-Corruption Laws of Mauritius or if there be a substantive suspicion in this regard, he will inform the relevant authority(ies) and in addition can initiate disciplinary actions. Furthermore, such bid shall be rejected.

5. Eligible Bidders

- 5.1 (a) Subject to ITB 5.4, A Bidder, and all parties constituting the Bidder, may have the nationality of any country. A Bidder shall be deemed to have the nationality of a country if the Bidder is a citizen or is constituted, incorporated, or registered and operates in conformity with the provisions of the laws of that country. This criterion shall also apply to the determination of the nationality of proposed subcontractors or suppliers for any part of the Contract including Related Services.
- (b) A Bidder may be a natural person, private entity, government-owned entity (subject to ITB 5.5) or any combination of them with a formal intent to enter into an agreement or under an existing agreement in the form of a Joint Venture (JV). In the case of a JV:
- (i) all parties to the JV shall be jointly and severally liable; and
 - (ii) a JV shall nominate a Representative who shall have the authority to conduct all businesses for and on behalf of any and all the parties of the JV during the bidding process and, in the event the JV is awarded the Contract, during contract execution.
- 5.2 A Bidder shall not have conflict of interest. All bidders found to have conflict of interest shall be disqualified. A Bidder may be considered to be in a conflict of interest with one or more parties in this bidding process if, including but not limited to:
- (a) have controlling shareholders in common; or
 - (b) receive or have received any direct or indirect subsidy from any of them; or
 - (c) have the same legal representative for purposes of this Bid; or
 - (d) have a relationship with each other, directly or through common third parties, that puts them in a position to have

access to information about or influence on the Bid of another Bidder, or influence the decisions of the Purchaser regarding this bidding process; or

- (e) a Bidder participates in more than one bid in this bidding process. Participation by a Bidder in more than one Bid will result in the disqualification of all Bids in which it is involved. However, this does not limit the inclusion of the same subcontractor, not otherwise participating as a Bidder, in more than one bid; or
 - (f) a Bidder or any of its affiliates participated as a consultant in the preparation of the design or technical specifications of the goods and services that are the subject of the bid.
- 5.3 (a) A Bidder that is under a declaration of ineligibility by the Government of Mauritius in accordance with applicable laws at the date of the deadline for bid submission or thereafter, shall be disqualified.

(b) Bids from suppliers appearing on the ineligibility lists of African Development Bank, Asian Development Bank, European Bank for Reconstruction and Development, Inter-American Development Bank Group and World Bank Group shall be rejected.

Links for checking the ineligibility lists are available on the PPO's website: *ppo.govmu.org*

- 5.4 A firm shall be excluded if by an act of compliance with a decision of the United Nations Security Council taken under Chapter VII of the Charter of the United Nations, Mauritius prohibits any import of goods or contracting of Works or services from a country where it is based or any payment to persons or entities in that country.
- 5.5 Government-owned enterprises in the Republic of Mauritius shall be eligible only if they can establish that they:
- (i) are legally and financially autonomous;
 - (ii) operate under commercial law, and
 - (iii) are not a dependent agency of the Purchaser.
- 5.6 Bidders shall provide such evidence of their continued

eligibility satisfactory to the Purchaser, as the Purchaser shall reasonably request.

- 6. Eligible Goods and Related Services**
- 6.1 All the Goods and Related Services to be supplied under the Contract may have their origin in any country subject to ITB 5.3 and 5.4.
- 6.2 For purposes of this Clause, the term “goods” includes commodities, raw material, machinery, equipment, industrial plants and “related services” which include services such as insurance, installation, training, and initial maintenance.
- 6.3 The term “origin” means the country where the goods have been mined, grown, cultivated, produced, manufactured or processed; or, through manufacture, processing, or assembly, another commercially recognized article results that differs substantially in its basic characteristics from its components.

B. Contents of Bidding Documents

- 7. Sections of Bidding Documents**
- 7.1 The Bidding Documents consist of Parts 1, 2, and 3, which include all the Sections indicated below, and should be read in conjunction with any Addendum issued in accordance with ITB Clause 9.

PART 1 Bidding Procedures

- Section I. Instructions to Bidders (ITB)
- Section II. Bidding Data Sheet (BDS)
- Section III. Evaluation and Qualification Criteria
- Section IV. Bidding Forms

PART 2 Supply Requirements

- Section V. Schedule of Requirements

PART 3 Contract

- Section VI. General Conditions of Contract (GCC)
- Section VII. Special Conditions of Contract (SCC)
- Section VIII. Contract Forms

- 7.2 The Invitation for Bids issued by the Purchaser is not part of the

Bidding Documents.

- 7.3 The Purchaser is not responsible for the completeness of the Bidding Documents and their addendum, if they were not obtained directly from the Purchaser.
- 7.4 The Bidder is expected to examine all instructions, forms, terms, and specifications in the Bidding Documents. Failure to furnish all information or documentation required by the Bidding Documents may result in the rejection of the bid.

8. Clarification of Bidding Documents

- 8.1 A prospective Bidder requiring any clarification of the Bidding Documents shall contact the Purchaser in writing at the Purchaser's address **specified in the BDS**. The Purchaser will respond in writing to any request for clarification, provided that such request is received 14 days prior to the deadline set for submission of bids. The Purchaser shall respond to such request at latest 7 days prior to the deadline for submission of bids and forward copies of its response to all those who have acquired the Bidding Documents directly from it, including a description of the inquiry but without identifying its source. Should the Purchaser deem it necessary to amend the Bidding Documents as a result of a clarification, it shall do so following the procedure under ITB Clause 9 and ITB Sub-Clause 25.2.

9. Amendment of Bidding Documents

- 9.1 At any time prior to the deadline for submission of bids, the Purchaser may amend the Bidding Documents by issuing addendum.
- 9.2 Any addendum issued shall be part of the Bidding Documents and shall be communicated in writing to all who have obtained the Bidding Documents directly from the Purchaser.
- 9.3 To give prospective Bidders reasonable time in which to take an addendum into account in preparing their bids, the Purchaser may, at its discretion, extend the deadline for the submission of bids, pursuant to ITB Sub-Clause 25.2

C. Preparation of Bids

10. Cost of Bidding

- 10.1 The Bidder shall bear all costs associated with the preparation and submission of its bid, and the Purchaser shall not be responsible or liable for those costs, regardless of the conduct or outcome of the bidding process.

11. Language of Bid

- 11.1 The Bid, as well as all correspondences and documents relating to the bid exchanged by the Bidder and the Purchaser, shall be written in English. Supporting documents and printed literature that are part of the Bid may be in another language provided they

are accompanied by an accurate translation of the relevant passages in English, in which case, for purposes of interpretation of the Bid, such translation shall govern.

11.2 Notwithstanding the above, documents in French submitted with the bid may be accepted without translation.

**12. Documents
Comprising
the Bid**

12.1 The Bid shall comprise the following:

- (a) the Bid Submission Form and the applicable Price Schedules, in accordance with ITB Clauses 13, 15, and 16;
- (b) the Bid Security or Bid-Securing Declaration, in accordance with ITB Clause 22, if required;
- (c) written confirmation authorizing the signatory of the Bid to commit the Bidder, in accordance with ITB Clause 23.2; **as specified in the BDS.**
- (d) documentary evidence in accordance with ITB Clause 17 establishing the Bidder's eligibility to bid;
- (e) documentary evidence in accordance with ITB Clause 18, that the Goods and Related Services to be supplied by the Bidder are of eligible origin;
- (f) documentary evidence in accordance with ITB Clauses 19 and 31, that the Goods and Related Services conform to the Bidding Documents;
- (g) documentary evidence in accordance with ITB Clause 20 establishing the Bidder's qualifications to perform the contract if its bid is accepted, and
- (h) any other document **required in the BDS.**

**13. Bid
Submission
Form and
Price
Schedules**

13.1 The Bidder shall submit the Bid Submission Form using the form furnished in Section IV, Bidding Forms. This form must be completed without any alteration to its format, and no substitutes shall be accepted. All blank spaces shall be filled in with the information requested.

13.2 The Bidder shall submit the Price Schedules for Goods and Related Services, according to their origin as appropriate, using the forms furnished in Section IV, Bidding Forms

**14. Alternative
Bids**

14.1 Unless otherwise **specified in the BDS**, alternative bids shall not be considered.

15. Bid Prices

15.1 The prices and discounts quoted by the Bidder in the Bid

**and
Discounts**

Submission Form and in the Price Schedules, shall conform to the requirements specified below.

- 15.2 All lots and items must be listed and priced separately in the Price Schedules.
- 15.3 The price to be quoted in the Bid Submission Form shall be the total price of the bid, excluding any discount offered.
- 15.4 The Bidder shall quote any unconditional discount and indicate the method for their application in the Bid Submission Form.
- 15.5 The terms EXW, CIP, CIF and other similar terms shall be governed by the rules prescribed in the current edition of Incoterms, published by The International Chamber of Commerce, as specified in the **BDS**.
- 15.6 Prices shall be quoted as specified in each Price Schedule included in Section IV, Bidding Forms. The disaggregation of price components is required solely for the purpose of facilitating the comparison of Bids by the Purchaser. This shall not in any way limit the Purchaser's right to contract on any of the terms offered. In quoting prices, the Bidder shall be free to use transportation through the carriers registered in any eligible country. Similarly, the Bidder may obtain insurance services from any eligible country. Prices shall be entered in the following manner:
 - (a) For Goods offered from within Mauritius :
 - (i) the price of the goods quoted EXW (ex-works, ex-factory, ex warehouse, ex showroom, or off-the-shelf, as applicable), including all customs duties already paid or payable on the components and raw material used in the manufacture or assembly of goods quoted ex works or ex-factory, or on the previously imported goods of foreign origin quoted ex-warehouse, ex-showroom, or off-the-shelf;
 - (ii) VAT payable on the Goods if the Contract is awarded to the Bidder; and
 - (iii) the total price for the item.
 - (b) For Goods offered from outside Mauritius :
 - (i) the price of the goods quoted CIF (named port of destination), or CIP (named place of destination), in the Mauritius, as specified in the **BDS**;
 - (ii) the price of the goods quoted FOB port of shipment (or FCA, as the case may be), if specified in the **BDS**;
 - (iii) the total price for the item.
 - (c) For Related Services whenever such Related Services are

specified in the Schedule of Requirements:

- (i) the local currency cost component of each item comprising the Related Services; and
- (ii) the foreign currency cost component of each item comprising the Related Services,

inclusive of custom duties and VAT, payable on the Related Services, if the Contract is awarded to the Bidder.

15.7 Prices quoted by the Bidder shall be fixed during the Bidder's performance of the Contract and not subject to variation on any account in respect of changes in production cost, unless otherwise specified in the **BDS**. A Bid submitted with an adjustable price quotation in this respect shall be treated as non-responsive and shall be rejected, pursuant to ITB Clause 31. However, if in accordance with the **BDS**, prices quoted by the Bidder shall be subject to adjustment during the performance of the Contract, a bid submitted with a fixed price quotation shall not be rejected, but the price adjustment shall be treated as zero.

15.8 If so indicated in ITB Sub-Clause 1.1, bids are being invited for individual contracts (lots) or for any combination of contracts (packages). Unless otherwise indicated in the **BDS**, prices quoted shall correspond to 100 % of the items specified for each lot and to 100% of the quantities specified for each item of a lot. Bidders wishing to offer any price reduction (discount) for the award of more than one Contract shall specify the applicable price reduction in accordance with ITB Sub-Clause 15.4 provided the bids for all lots are submitted and opened at the same time.

16. Currencies of Bid

16.1 The Bidder shall quote in Mauritian Rupees the portion of the bid price that corresponds to expenditures incurred in Mauritian Rupees, unless otherwise specified in the **BDS**.

16.2 The Bidder may express the bid price in the currency of any eligible country. If the Bidder wishes to be paid in a combination of amounts in different currencies, it may quote its price accordingly but shall use no more than three currencies in addition to Mauritian Rupees.

16.3 Local Bidders shall quote only in Mauritian Rupees **as specified in the BDS**.

17. Documents Establishing the Eligibility of

17.1 To establish their eligibility in accordance with ITB Clause 5, Bidders shall complete the Bid Submission Form, included in Section IV: Bidding Forms.

the Bidder

- 18. Documents Establishing the Eligibility of the Goods and Related Services**
- 18.1 To establish the eligibility of the Goods and Related Services in accordance with ITB Clause 6, Bidders shall complete the country of origin declarations in the Price Schedule Forms, included in Section IV, Bidding Forms.
- 19. Documents Establishing the Conformity of the Goods and Related Services**
- 19.1 To establish the conformity of the Goods and Related Services to the Bidding Documents, the Bidder shall furnish as part of its Bid the documentary evidence that the Goods conform to the technical specifications and standards specified in Section V, Schedule of Requirements.
- 19.2 The documentary evidence may be in the form of literature, drawings or data, and shall consist of a detailed item by item description of the essential technical and performance characteristics of the Goods and Related Services, demonstrating substantial responsiveness of the Goods and Related Services to the technical specification, and if applicable, a statement of deviations and exceptions to the provisions of the Schedule of Requirements.
- 19.3 The Bidder shall also furnish a list giving full particulars, including available sources and current prices of spare parts, special tools, etc., necessary for the proper and continuing functioning of the Goods during the period **specified in the BDS** following commencement of the use of the goods by the Purchaser.
- 19.4 Standards for workmanship, process, material, and equipment, as well as references to brand names or catalogue numbers specified by the Purchaser in the Schedule of Requirements, are intended to be descriptive only and not restrictive. The Bidder may offer other standards of quality, brand names, and/or catalogue numbers, provided that it demonstrates, to the Purchaser's satisfaction, that the substitutions ensure substantial equivalence or are superior to those specified in the Schedule of Requirements.
- 20. Documents Establishing the Qualifications of the Bidder**
- 20.1 The documentary evidence of the Bidder's qualifications to perform the contract if its bid is accepted shall establish to the Purchaser's satisfaction that:
- (a) if **required in the BDS**, a Bidder that does not manufacture or produce the Goods it offers to supply shall submit the Manufacturer's Authorization using the form included in

Section IV, Bidding Forms, to demonstrate that it has been duly authorized by the manufacturer or producer of the Goods to supply these Goods in Mauritius;

- (b) if **required in the BDS**, in case of a Bidder not doing business within Mauritius, the Bidder is or will be (if awarded the contract) represented by an Agent in Mauritius equipped and able to carry out the Supplier's maintenance, repair and spare parts-stocking obligations prescribed in the Conditions of Contract and/or Technical Specifications; and
- (c) the Bidder meets each of the qualification criterion specified in Section III, Evaluation and Qualification Criteria.

21. Period of Validity of Bids

- 21.1 Bids shall remain valid for the period **specified in the BDS** after the bid submission deadline date prescribed by the Purchaser. A bid valid for a shorter period shall be rejected by the Purchaser as non-responsive.
- 21.2 In exceptional circumstances, prior to the expiration of the bid validity period, the Purchaser may request bidders to extend the period of validity of their bids. The request and the responses shall be made in writing. If a Bid Security is requested in accordance with ITB Clause 22, it shall also be extended for a corresponding period. A Bidder may refuse the request without forfeiting its Bid Security. A Bidder granting the request shall not be required or permitted to modify its bid, except as provided in ITB Sub-Clause 21.3.
- 21.3 In the case of fixed price contracts, if the award is delayed by a period exceeding fifty-six (56) days beyond the expiry of the initial bid validity, the Contract price shall be adjusted as specified in the request for extension. Bid evaluation shall be based on the Bid Price without taking into consideration the above correction.

22. Bid Security

- 22.1 The Bidder shall either furnish as part of its bid, a Bid Security or subscribe to a Bid Securing Declaration in the Bid Submission Form **as specified in the BDS**.
- 22.2 The Bid Securing Declaration shall be in the form of a signed subscription in the Bid Submission Form.
- 22.3 The Bid Security shall be in the amount **specified in the BDS** and denominated in Mauritian Rupees or a freely convertible

currency, and shall:

- (a) be in the form of a bank guarantee from a reputable overseas bank, or
- (b) be issued by a commercial bank or insurance company operating in Mauritius.
- (c) be substantially in accordance with the forms of Bid Security included in Section IV, Bidding Forms, or other form approved by the Purchaser prior to bid submission;
- (d) be payable promptly upon written demand by the Purchaser in case the conditions listed in ITB Clause 22.6 are invoked;
- (e) be submitted in its original form; copies will not be accepted;
- (f) remain valid for a period of 30 days beyond the validity period of the bids, as extended, if applicable, in accordance with ITB Clause 21.2;

22.4 Any bid not accompanied by an enforceable and substantially compliant Bid Security or not containing a subscription to a Bid Securing Declaration in the Bid Submission Form, if required, in accordance with ITB 22.1, shall be rejected by the Purchaser as nonresponsive.

22.5 The Bid Security of unsuccessful Bidders shall be returned as promptly as possible upon the successful Bidder's furnishing of the Performance Security pursuant to ITB Clause 45.

22.6 The Bid Security shall be forfeited or the Bid Securing Declaration executed:

- (a) if a Bidder withdraws its bid during the period of bid validity specified by the Bidder on the Bid Submission Form, except as provided in ITB Sub-Clause 21.2; or
- (b) if a Bidder refuses to accept a correction of an error appearing on the face of the Bid; or
- (c) if the successful Bidder fails to: sign the Contract in accordance with ITB 44; or furnish a performance security in accordance with ITB 45;

22.7 The Bid Security or Bid- Securing Declaration of a Joint Venture (JV) must be in the name of the JV that submits the bid. If the JV

has not been legally constituted at the time of bidding, the Bid Security or Bid-Securing Declaration shall be in the names of all future partners as named in the letter of intent mentioned in Section IV “Bidding Forms,” Bidder Information Form Item 7.

22.8 If a bid security is **not required in the BDS**, and

- (a) if a Bidder withdraws its bid during the period of bid validity specified by the Bidder on the Letter of Bid Form, except as provided in ITB 21.2;
- (b) if a Bidder refuses to accept a correction of an error appearing on the face of the Bid; or
- (c) if the successful Bidder fails to: sign the Contract in accordance with ITB 43; or furnish a performance security in accordance with ITB 44.

the bidder may be disqualified by the Government of Mauritius to be awarded a contract by any Public Body for a period of time.

23. Format and Signing of Bid

- 23.1 The Bidder shall prepare one original of the documents comprising the bid as described in ITB Clause 12 and clearly mark it “ORIGINAL.” In addition, the Bidder shall submit copies of the bid, in the number specified in the **BDS** and clearly mark them “COPY.” In the event of any discrepancy between the original and the copies, the original shall prevail.
- 23.2 The original and all copies of the bid shall be typed or written in indelible ink and shall be signed by a person duly authorized to sign on behalf of the Bidder.
- 23.3 Any interlineation, erasure, or overwriting shall be valid only if it is signed or initialed by the person signing the Bid.

D. Submission and Opening of Bids

24. Submission, Sealing and Marking of Bids

- 24.1 Bidders may always submit their bids by mail or by hand. When so specified in the **BDS**, bidders shall have the option of submitting their bids electronically.
- (a) Bidders submitting bids by mail or by hand, shall enclose the original and each copy of the Bid, including alternative bids, if permitted in accordance with ITB Clause 14, in separate sealed envelopes, duly marking the envelopes as “ORIGINAL” and “COPY.” These envelopes containing the original and the copies shall then be enclosed in one single envelope. The rest of the procedure shall be in accordance with ITB sub-Clauses 24.2 and 24.3.

- (b) Bidders submitting bids electronically shall follow the electronic bid submission procedures specified in the **BDS**.
- 24.2 The inner and outer envelopes shall:
- (a) bear the name and address of the Bidder;
 - (b) be addressed to the Purchaser in accordance with ITB Sub-Clause 25.1;
 - (c) bear the specific identification of this bidding process indicated in ITB 1.1 and any additional identification marks as **specified in the BDS**, and
 - (d) bear a warning not to open before the time and date for bid opening, in accordance with ITB Sub-Clause 28.1.
- 24.3 If all envelopes are not sealed and marked as required, the Purchaser will assume no responsibility for the misplacement or premature opening of the bid.
- 25. Deadline for Submission of Bids**
- 25.1 Bids must be received by the Purchaser at the address and not later than the date and time **specified in the BDS**.
- 25.2 The Purchaser may, at its discretion, extend the deadline for the submission of bids by amending the Bidding Documents in accordance with ITB Clause 9, in which case all rights and obligations of the Purchaser and Bidders previously subject to the deadline shall thereafter be subject to the deadline as extended.
- 26. Late Bids**
- 26.1 The Purchaser shall not consider any bid that arrives after the deadline for submission of bids, in accordance with ITB Clause 25. Any bid received by the Purchaser after the deadline for submission of bids shall be declared late, rejected, and returned unopened to the Bidder.
- 27. Withdrawal, Substitution, and Modification of Bids**
- 27.1 A Bidder may withdraw, substitute, or modify its Bid after it has been submitted by sending a written notice in accordance with ITB Clause 24, duly signed by an authorized representative, and shall include a copy of the authorization (the power of attorney) in accordance with ITB Sub-Clause 23.2, (except that no copies of the withdrawal notice are required). The corresponding substitution or modification of the bid must accompany the respective written notice. All notices must be:
- (a) submitted in accordance with ITB Clauses 23 and 24 (except that withdrawal notices do not require copies), and in addition, the respective envelopes shall be clearly marked “WITHDRAWAL,” “SUBSTITUTION,” or

“MODIFICATION;” and

- (b) received by the Purchaser prior to the deadline prescribed for submission of bids, in accordance with ITB Clause 25.

27.2 Bids requested to be withdrawn in accordance with ITB Sub-Clause 27.1 shall be returned unopened to the Bidders.

27.3 No bid may be withdrawn, substituted, or modified in the interval between the deadline for submission of bids and the expiration of the period of bid validity specified by the Bidder on the Bid Submission Form or any extension thereof.

28. Bid Opening 28.1 The Purchaser shall conduct the bid opening in the presence of the Bidders’ representatives who choose to attend at the address, date and time **specified in the BDS**. Any specific electronic bid opening procedures required if electronic bidding is permitted in accordance with ITB Sub-Clause 24.1 shall be as **specified in the BDS**.

28.2 First, envelopes marked “WITHDRAWAL” shall be opened and read out and the envelope with the corresponding bid shall not be opened, but returned to the Bidder. No bid withdrawal shall be permitted unless the corresponding withdrawal notice contains a valid authorization to request the withdrawal and is read out at bid opening. Next, envelopes marked “SUBSTITUTION” shall be opened and read out and exchanged with the corresponding Bid being substituted, and the substituted Bid shall not be opened, but returned to the Bidder. No Bid substitution shall be permitted unless the corresponding substitution notice contains a valid authorization to request the substitution and is read out at bid opening. Envelopes marked “MODIFICATION” shall be opened and read out with the corresponding Bid. No Bid modification shall be permitted unless the corresponding modification notice contains a valid authorization to request the modification and is read out at Bid opening. Only envelopes that are opened and read out at Bid opening shall be considered further.

28.3 All other envelopes shall be opened one at a time, reading out: the name of the Bidder; the Bid Price(s), including any discounts and alternative bids and indicating whether there is a modification; the presence of a bid security or the subscription with respect to the Bid Securing Declaration in the Bid Submission Form, if required; and any other details as the Purchaser may consider appropriate. Only discounts and alternative offers read out at bid opening shall be considered for evaluation. No bid shall be rejected at bid opening except for late

bids, in accordance with ITB 26.1.

- 28.4 The Purchaser shall prepare a record of the Bid opening that shall include, as a minimum: the name of the Bidder and whether there is a withdrawal, substitution, or modification; the Bid Price, per lot if applicable, including any discounts, and alternative offers if they were permitted; and the presence or absence of a Bid Security, if one was required. The Bidders' representatives who are present shall be requested to sign the record. The omission of a bidder's signature on the record shall not invalidate the contents and the effect of the record. A copy of the record shall be distributed, upon request, to all Bidders who submitted bids in time; and posted on line when electronic bidding is permitted.

E. Evaluation and Comparison of Bids

- 29. Confidentiality** 29.1 Information relating to the examination, evaluation, comparison, and post-qualification of bids, and recommendation of contract award, shall not be disclosed to bidders or any other persons not officially concerned with such process until publication of the Contract Award.
- 29.2 Any effort by a Bidder to influence the Purchaser in the examination, evaluation, comparison, and post-qualification of the bids or contract award decisions may result in the rejection of its Bid.
- 29.3 Notwithstanding ITB Sub-Clause 29.2, from the time of bid opening to the time of Contract Award, if any Bidder wishes to contact the Purchaser on any matter related to the bidding process, it should do so in writing.
- 30. Clarification of Bids** 30.1 To assist in the examination, evaluation, comparison and post-qualification of the bids, the Purchaser may, at its discretion, ask any Bidder for a clarification of its Bid. Any clarification submitted by a Bidder in respect to its Bid and that is not in response to a request by the Purchaser shall not be considered. The Purchaser's request for clarification and the response shall be in writing. No change in the prices or substance of the Bid shall be sought, offered, or permitted, except to confirm the correction of arithmetic errors discovered by the Purchaser in the Evaluation of the bids, in accordance with ITB Clause 32.
- 31. Responsiveness of Bids** 31.1 The Purchaser's determination of a bid's responsiveness is to be based on the contents of the bid itself.
- 31.2 A substantially responsive Bid is one that conforms to all the terms, conditions, and specifications of the Bidding Documents

without material deviation, reservation, or omission. A material deviation, reservation, or omission is one that:

- (a) affects in a substantial way the scope, quality, or performance of the Goods and Related Services specified in the Contract; or
- (b) limits in a substantial way, inconsistent with the Bidding Documents, the Purchaser's rights or the Bidder's obligations under the Contract; or
- (c) if rectified, would unfairly affect the competitive position of other bidders presenting substantially responsive bids.

31.3 If a bid is not substantially responsive to the Bidding Documents, it shall be rejected by the Purchaser and may not subsequently be made responsive by the Bidder by correction of the material deviation, reservation, or omission.

32. Nonconformities, Errors, and Omissions

32.1 Provided that a Bid is substantially responsive, the Purchaser may waive any non-conformities or omissions in the Bid that do not constitute a material deviation.

32.2 Provided that a bid is substantially responsive, the Purchaser may request the Bidder to submit the necessary information or documentation, within a reasonable period of time, or to rectify nonmaterial nonconformities or omissions in the bid relating to documentation requirements. Such omission shall not be related to any aspect of the price of the Bid. Failure of the Bidder to comply with the request may result in the rejection of its Bid.

32.3 Provided that the Bid is substantially responsive, the Purchaser shall correct arithmetical errors on the following basis:

- (a) if there is a discrepancy between the unit price and the line item total that is obtained by multiplying the unit price by the quantity, the unit price shall prevail and the line item total shall be corrected, unless in the opinion of the Purchaser there is an obvious misplacement of the decimal point in the unit price, in which case the line item total as quoted shall govern and the unit price shall be corrected;
- (b) if there is an error in a total corresponding to the addition or subtraction of subtotals, the subtotals shall prevail and the total shall be corrected; and
- (c) if there is a discrepancy between words and figures, the amount in words shall prevail, unless the amount expressed in words is related to an arithmetic error, in which case the

amount in figures shall prevail subject to (a) and (b) above.

- 33. Preliminary Examination of Bids**
- 33.1 The Purchaser shall examine the bids to confirm that all documents and technical documentation requested in ITB Clause 12 have been provided, and to determine the completeness of each document submitted.
- 33.2 The Purchaser shall confirm that the following documents and information have been provided in the Bid. If any of these documents or information is missing, the offer shall be rejected.
- (a) Bid Submission Form, in accordance with ITB Sub-Clause 13.1;
 - (b) Price Schedules, in accordance with ITB Sub-Clause 13.2;
 - (c) Bid Security or Bid Securing Declaration, in accordance with ITB Clause 22, if applicable.
- 34. Examination of Terms and Conditions; Technical Evaluation**
- 34.1 The Purchaser shall examine the Bid to confirm that all terms and conditions specified in the GCC and the SCC have been accepted by the Bidder without any material deviation or reservation.
- 34.2 The Purchaser shall evaluate the technical aspects of the Bid submitted in accordance with ITB Clause 19, to confirm that all requirements specified in Section V, Schedule of Requirements of the Bidding Documents have been met without any material deviation or reservation.
- 34.3 If, after the examination of the terms and conditions and the technical evaluation, the Purchaser determines that the Bid is not substantially responsive in accordance with ITB Clause 31, it shall reject the Bid.
- 35. Conversion to Single Currency**
- 35.1 For evaluation and comparison purposes, the Purchaser shall convert all bid prices expressed in amounts in various currencies into an amount in a single currency **specified in the BDS**, using the selling exchange rates established by **Central Bank of Mauritius** and on the date **specified in the BDS**.
- 36. Margin of Preference**
- 36.1 Margin of preference shall not be a factor in bid evaluation, unless otherwise **specified in the BDS**.
- 37. Evaluation of Bids**
- 37.1 The Purchaser shall evaluate each bid that has been determined, up to this stage of the evaluation, to be substantially responsive.
- 37.2 To evaluate a Bid, the Purchaser shall use only the factors, methodologies and criteria defined in ITB Clause 37. No other

criteria or methodology shall be permitted.

37.3 To evaluate a Bid, the Purchaser shall consider the following:

- (a) evaluation to be done for Items or Lots, as **specified in the BDS**; and the Bid Price as quoted in accordance with clause 15;
- (b) price adjustment for correction of arithmetic errors in accordance with ITB Sub-Clause 32.3;
- (c) price adjustment due to discounts offered in accordance with ITB Sub-Clause 15.4;
- (d) adjustments due to the application of the evaluation criteria **specified in the BDS** from amongst those set out in Section III, Evaluation and Qualification Criteria;
- (e) adjustments due to the application of a margin of preference, in accordance with ITB Clause 36 if applicable.

37.4 (a) The Purchaser's evaluation of a bid will take into account:

- (i) in the case of Goods offered from within Mauritius, all taxes but excluding VAT payable on the Goods if the Contract is awarded to the Bidder;
- (ii) in the case of Goods offered from outside Mauritius, customs duties applicable in and payable on the Goods if the Contract is awarded to the Bidder; and
- (iii) transport and other costs for the goods to reach its final destination.

(b) The Purchaser's evaluation of a bid will **not** take into account any allowance for price adjustment during the period of performance of the Contract, if provided in the Bid.

37.5 The Purchaser's evaluation of a bid may require the consideration of other factors, in addition to the Bid Price quoted in accordance with ITB Clause 15. These factors may be related to the characteristics, performance, and terms and conditions of purchase of the Goods and Related Services. The effect of the factors selected, if any, shall be expressed in monetary terms to facilitate comparison of bids, unless otherwise specified in Section III, Evaluation and Qualification Criteria. The factors, methodologies and criteria to be used shall be as specified in ITB 37.3 (d).

37.6 If so **specified in the BDS**, these Bidding Documents shall allow Bidders to quote separate prices for one or more lots, and shall allow the Purchaser to award one or multiple lots to more

than one Bidder. The methodology of evaluation to determine the lowest-evaluated lot combinations, is specified in Section III, Evaluation and Qualification Criteria.

- 38. Comparison of Bids** 38.1 The Purchaser shall compare all substantially responsive bids to determine the lowest-evaluated bid, in accordance with ITB Clause 37.
- 39. Post-qualification of the Bidder**
- 39.1 The Purchaser shall determine to its satisfaction whether the Bidder that is selected as having submitted the lowest evaluated and substantially responsive bid is qualified to perform the Contract satisfactorily.
- 39.2 The determination shall be based upon an examination of the documentary evidence of the Bidder's qualifications submitted by the Bidder, pursuant to ITB Clause 20.
- 39.3 An affirmative determination shall be a prerequisite for award of the Contract to the Bidder. A negative determination shall result in disqualification of the bid, in which event the Purchaser shall proceed to the next lowest evaluated bid to make a similar determination of that Bidder's capabilities to perform satisfactorily.
- 39.4 Notwithstanding anything stated above, the Purchaser reserves the right to assess the Bidder's capabilities and capacity to execute the Contract satisfactorily before deciding on award.
- 40. Purchaser's Right to Accept Any Bid, and to Reject Any or All Bids** 40.1 The Purchaser reserves the right to accept or reject any bid, and to annul the bidding process and reject all bids at any time prior to contract award, without thereby incurring any liability to Bidders.

F. Award of Contract

- 41. Award Criteria** 41.1 The Purchaser shall award the Contract to the Bidder whose offer has been determined to be the lowest evaluated bid and is substantially responsive to the Bidding Documents, provided further that the Bidder is determined to be qualified to perform the Contract satisfactorily.
- 42. Purchaser's Right to Vary Quantities at Time of** 42.1 At the time the Contract is awarded, the Purchaser reserves the right to increase or decrease the quantity of Goods and Related Services originally specified in Section V, Schedule of Requirements, provided this does not exceed the percentages **specified in the BDS**, and without any change in the unit prices or other terms and conditions of the bid and the Bidding

- Award Documents.**
- 43. Notification of Award**
- 43.1 Prior to the expiration of the period of bid validity, the Purchaser shall, for contract amount above the prescribed threshold, notify the selected bidder of the proposed award and accordingly notify unsuccessful bidders. Subject to Challenge and Appeal the Purchaser shall notify the selected Bidder, in writing, by a Letter of Acceptance for award of contract. The Letter of Acceptance shall specify the sum that the Purchaser will pay the Supplier in consideration of the execution and completion of the Contract (hereinafter and in the Conditions of Contract and Contract Forms called “the Contract Price”). Within seven days from the issue of Letter of Acceptance, the Purchaser shall publish on the Public Procurement Portal (publicprocurement.govmu.org) and the Purchaser’s website, the results of the Bidding Process identifying the bid and lot numbers and the following information:
- (i) name of the successful Bidder, and the Price it offered, as well as the duration and summary scope of the contract awarded; and
 - (ii) an executive summary of the Bid Evaluation Report
- 43.2 Until a formal Contract is prepared and executed, the letter of Acceptance shall constitute a binding Contract.
- 44. Signing of Contract**
- 44.1 Promptly after issue of letter of acceptance, the Purchaser shall send the successful Bidder the Agreement and the Special Conditions of Contract.
- 44.2 Within twenty-eight (28) days of receipt of the Agreement, the successful Bidder shall sign, date, and return it to the Purchaser.
- 44.3 Notwithstanding ITB 44.2 above, in case signing of the Contract Agreement is prevented by any export restrictions attributable to the Purchaser, to Mauritius, or to the use of the products/goods, systems or services to be supplied, where such export restrictions arise from trade regulations from a country supplying those products/goods, systems or services, the Bidder shall not be bound by its bid, always provided, however, that the Bidder can demonstrate to the satisfaction of the Purchaser that signing of the Contact Agreement has not been prevented by any lack of diligence on the part of the Bidder in completing any formalities, including applying for permits, authorizations and licenses necessary for the export of the products/goods, systems or services under the terms of the Contract.
- 45. Performanc**
- 45.1 Within twenty eight (28) days of the receipt of letter of

e Security

Acceptance from the Purchaser, the successful Bidder, if required, shall furnish the Performance Security in accordance with the GCC, using for that purpose the Performance Security Form included in Section VIII Contract forms, or another Form acceptable to the Purchaser. The Purchaser shall promptly notify the name of the winning Bidder to each unsuccessful Bidder and discharge the Bid Securities of the unsuccessful bidders pursuant to ITB Sub-Clause 22.4.

45.2 Failure of the successful Bidder to submit the above-mentioned Performance Security or sign the Contract shall lead to the annulment of the award and forfeiture of the Bid Security or execution of the Bid-Securing Declaration. In that event the Purchaser may award the Contract to the next lowest evaluated Bidder, whose offer is substantially responsive and is determined by the Purchaser to be qualified to perform the Contract satisfactorily.

46. Debriefing

46.1 The Purchaser shall promptly attend to all debriefing for the contract made in writing and within 30 days from the date of the publication of the award or date the unsuccessful bidders are informed about the award, whichever is the case by following regulation 9 of the Public Procurement Regulations 2008 as amended.

Section II. Bidding Data Sheet (BDS)

The following specific data for the goods to be procured shall complement, supplement, or amend the provisions in the Instructions to Bidders (ITB). Whenever there is a conflict, the provisions herein shall prevail over those in ITB.

ITB Clause Reference	A. General
ITB 1.1	The Purchaser is: Irrigation Authority
ITB 1.1	<p>The name and identification number of the Procurement is: OMD/SPAREPARTS/07/23</p> <p>The Invitation for Bids has been issued through an Open National Bidding procedure.</p>
ITB 1.1	The name of the Project is: SUPPLY OF SPARE PARTS
ITB 2.1	The Funding Agency is the Government of the Republic of Mauritius which will disburse the fund to the Irrigation Authority

ITB 3.3	<p>(a) The address to file challenge in respect of this procurement is:</p> <p>The General Manager Irrigation Authority 5th Floor, Fon Sing Building 12 Edith Cavell Street, Port Louis Tel: 210 6596 Fax: 212 7652</p> <p>(b) The address to file application for review is:</p> <p>The Chairperson Independent Review Panel, 5th Floor Belmont House Intendance Street Port Louis Tel : +2302602228 Fax No. Email : irp@govmu.org</p>
ITB 5.3	<p>A list of firms debarred from participating in Public Procurement in Mauritius is available at ppo.govmu.org</p> <p>A list of firms debarred by World Bank is available at http://www.worldbank.org/debarr.</p>
B. Contents of Bidding Documents	
ITB 8.1	<p>For <u>Clarification of bid purposes</u> only, the Purchaser's address is:</p> <p>The General Manager Irrigation Authority 5th Floor, Fon Sing Building 12 Edith Cavell Street, Port Louis Tel: 210 6596 Fax: 212 7652</p>

ITB 8.1	<p>The IA shall respond to requests for clarification received earlier than (7) seven days prior to the deadline for submission of bids.</p> <p>All queries received within the deadline set and reply thereto will be available on the IA's website: https://ia.govmu.org/procurement/tender</p>
	C. Preparation of Bids
ITB 12.1 (h)	<p>The Bidder shall submit the following additional documents in its bid: Company Profile with Audited Financial Statements for the last three years namely 2020, 2021 and 2022.</p> <p>(a) Technical Documentation/Catalogues/brochures/data sheets and all other documents requested for as at Section V-Technical Specification.</p> <p>(b) Documents to respond to Evaluation Criteria mentioned in Section III</p>
ITB 14.1	<p>Only One alternative bid may be considered if it suits the Authority upon appraisal.</p>
ITB 15.5	<p>The Incoterms edition is: Incoterms 2020</p>
ITB 15.6(b) (i), (ii)	<p>For Goods offered from outside Mauritius, the Bidder shall quote prices using the following Incoterms: Delivery Duty Paid (DDP) wherever applicable. These goods are used for installation in irrigation pipe network.</p>
ITB 15.7	<p>Bidders shall quote a firm and fixed price and price is not subject to any variation</p>
ITB 15.8	<p>The employer reserves the right to award the contract on item wise basis with respect to the Bill of Quantity.</p>
ITB 16.1	<p>The Bidder is required to quote in Mauritian Rupees.</p>
ITB 16.3	<p>Local bidders shall quote only in Mauritian Rupees on the basis of prices not adjustable to rate of exchange.</p>

ITB 19.1	Bidders must submit the following documents to establishing the Conformity of the Goods: 1. Test Reports for sprinklers originating from manufacturers 2. Pamphlets/Catalogues/Drawings for items quoted
ITB 19.3	Period of time the Goods are expected to be functioning is 3 years .
ITB 20.1 (a)	Manufacturer's authorization is required.
ITB 20.1 (b)	After sales service is required.
ITB 21.1	The bid validity period shall be 90 days from the Bid Submission date.
ITB 22.1	The Bidder shall subscribe to a Bid Securing Declaration by signing the Bid Submission Form containing the provision with regard thereto.
ITB 22.3	Bid Security: Not Applicable
ITB 22.8	If the Bidder incurs any of the actions prescribed in subparagraphs (a) to (c) of this provision, the Bidder may be declared ineligible to be awarded contracts by the Government of Mauritius for a period of time to be determined by the relevant Authority.
ITB 23.1	In addition to the original of the bid, the number of copies is: ONE . Bidders should provide the original and copy of their bid in separate BINDERS with each set appropriately tabbed and identified with relevant headings.
D. Submission and Opening of Bids	
ITB 24.1	Bidders shall not have the option of submitting their bids electronically. Bids should be submitted in hard copies in the Tender Box at the address indicated in ITB 25.1 below.
ITB 24.1 (b)	Not Applicable
ITB 24.2 (c)	The envelope shall bear the following additional identification marks: OMD/ SPAREPARTS/07/23: Procurement for Supply of Spare Parts The warning should read DO NOT OPEN BEFORE Friday 5th May 2023, Time: 15hr30 (Mauritian time) at latest. Bidders should clearly mention their name and address on the back

	of the outer envelopes containing their bids so as to enable the Purchaser to return late bids unopened.
ITB 25.1	<p>For bid submission purposes, the Purchaser's address is:</p> <p>Irrigation Authority 5th Floor, Fon Sing Building 12 Edith Cavell Street, Port Louis, Republic of Mauritius</p> <p>The deadline for the submission of bids is: Date: Friday 5th May 2023, Time: 15hr00 hr (Mauritian time) at latest</p>
ITB 27.1	Not Applicable
ITB 28.1	<p>The bid opening shall take place in the Conference Room at:</p> <p>Irrigation Authority 5th Floor, Fon Sing Building 12 Edith Cavell Street, Port Louis, Republic of Mauritius</p> <p>Date: Friday 5th May 2023</p> <p>Time: As from 15hr30</p> <p>Bidders or their representatives may attend the Bid opening if they choose to do so.</p>
	E. Evaluation and Comparison of Bids
ITB 35.1	Bid prices shall be expressed in Mauritian Rupees
ITB 36.1	A margin of preference shall be applicable to local Small and Medium Enterprises as indicated in Section III.
ITB 37.3(a)	Evaluation will be done for each item as per the Bill of Quantity and award will be based on the responsive item implying the Purchaser will split the award item wise basis.

ITB 37.3(d)	The adjustments shall be determined using the following criteria, from amongst those set out in Section III, Evaluation and Qualification Criteria: (a) Deviation in Delivery schedule: No (b) Deviation in Payment schedule: No
ITB 37.6	The contract will be awarded item wise as per the Bill of Quantity.
	F. Award of Contract
ITB 42.1	The maximum percentage by which quantities may be increased or decreased is 30 %

Pre- Meeting

A pre-meeting is scheduled for **Friday 21 April 2023 at 10:00hrs at the Sub-Office at Plaine des Papayes.**

Right of the Public Body

The Irrigation Authority reserves the right to increase or decrease the quantities of any item to be ordered by the time of finalising the order list due to the requirement if found necessary.

All items are to be priced based on sea freight.

Section III. Evaluation and Qualification Criteria

Contents

1. Evaluation Criteria (ITB 37.3 (d))

The Technical Evaluation Criteria shall be based only on the technical data/information submitted by the bidder for major items in the BOQ.

2. Multiple Contracts (ITB 37.6)

3. Post qualification Requirements (ITB 39.2)

4. Domestic Preference (ITB 36.1)

1. Evaluation Criteria (ITB 37.3 (d))

The Purchaser's evaluation of a bid may take into account, in addition to the Bid Price quoted in accordance with ITB Clause 15.6, one or more of the following factors as specified in ITB Sub-Clause 37.3(d) and in BDS referring to ITB 37.3(d), using the following criteria and methodologies.

- (a) Delivery schedule. (as per Incoterms specified in the BDS)

The Goods specified in the List of Goods are required to be delivered within 90 calendar days or earlier as specified in Section VI, Delivery Schedule. No credit will be given to deliveries before the earliest date, and bids offering delivery after the final date shall be treated as non responsive. Within this acceptable period, an adjustment, as specified in BDS Sub-Clause 37.3(d), will be added, for evaluation purposes only, to the bid price of bids offering deliveries later than the "Earliest Delivery Date" specified in Section VI, Delivery Schedule.

- (b) Deviation in payment schedule.

(i) The SCC stipulates the payment schedule specified by the Purchaser.

- (c) Cost of major replacement components, mandatory spare parts, and service. *[insert one of the following]* **Not Applicable**

(i) *The list of items and quantities of major assemblies, components, and selected spare parts, likely to be required during the initial period of operation specified in the BDS Sub-Clause 19.3, is in the List of Goods. An adjustment equal to the total cost of these items, at the unit prices quoted in each bid, shall be added to the bid price, for evaluation purposes only.*

or

(ii) *The Purchaser will draw up a list of high-usage and high-value items of components and spare parts, along with estimated quantities of usage in the initial period of operation specified in the BDS Sub-Clause 19.3. The total cost of these items and quantities will be computed from spare parts unit prices submitted by the Bidder and added to the bid price, for evaluation purposes only.*

- (d) Availability in Mauritius of spare parts and after sales services for equipment offered in the bid for at least 5 years

- (e) Projected operating and maintenance costs. **Not Applicable**

An adjustment to take into account the operating and maintenance costs of the Goods will be added to the bid price, for evaluation purposes only, if specified in BDS Sub-Clause 37.3(d). The adjustment will be evaluated in accordance with the methodology specified in the BDS Sub-Clause 37.3(d).

- (f) Performance and productivity of the equipment. *[insert one of the following]* **Not Applicable**
- (i) An adjustment representing the capitalized cost of additional operating costs over the life of the plant will be added to the bid price for evaluation purposes if specified in the BDS Sub-Clause 37.3(d). The adjustment will be evaluated based on the drop in the guaranteed performance or efficiency offered in the bid below the norm of 100, using the methodology specified in BDS Sub-Clause 37.3(d).
- or**
- (ii) An adjustment to take into account the productivity of the goods offered in the bid will be added to the bid price for evaluation purposes only, if so specified in BDS Sub-Clause 37.3(d). The adjustment will be evaluated based on the cost per unit of the actual productivity of goods offered in the bid with respect to minimum required values, using the methodology specified in BDS Sub-Clause 37.3(d).
- (g) Specific additional criteria : Nil

2. Multiple Contracts (ITB 37.6) Not Applicable

The Purchaser shall award multiple contracts to the Bidder that offers the lowest evaluated combination of bids (one contract per bid) and meets the post-qualification criteria (Section III, Sub-Section ITB 39.2 Post-Qualification Requirements)

The Purchaser shall:

- (a) evaluate only lots or contracts that include at least the percentages of items per lot and quantity per item as specified in ITB Sub Clause 15.8
- (b) take into account:
- (a) the lowest-evaluated bid for each lot and
- (ii) the price reduction per lot and the methodology for its application as offered by the Bidder in its bid.

3. Post-qualification Requirements (ITB 39.2)

After determining the lowest-evaluated bid in accordance with ITB Sub-Clause 39.1, the Purchaser shall carry out the post-qualification of the Bidder in accordance with ITB Clause 39, using only the requirements specified. Requirements not included in the text below shall not be used in the evaluation of the Bidder's qualifications.

- (a) Financial Capability

Bidder shall furnish documentary evidence of the latest copy of the Audited Financial Statement for the last three Financial Years or any other such evidence to demonstrate that they have the financial capacity to perform under the contract.

(b) Qualification requirements:

- (i) The Bidder must have at least **Three (3)** years of experience in supply of spare parts
- (ii) The Bidder should also be equipped and able to carry out the maintenance, repairs, trouble shooting and the stocking of spare parts.
- (iii) The goods shall be delivered within 90 calendar days or earlier.

(c) Experience and Technical Capacity

The Bidder is requested to submit documentary evidence to demonstrate that it meets the following experience requirement:

- (i) During the last **three (3) years**, the bidder shall have at least undertaken three (3) contracts in Mauritius with regards to supply of spare parts.
- (ii) Client references where spare parts were supplied

The following details must be provided:

Name and contact details of the Client/s

Original contract sum,

Date for completion of the contract

4. Margin of Preference (ITB 36.1)

Small and Medium Enterprises (SME), registered with the SME Mauritius Ltd and submitting the “Made in Moris” certification issued by the Association of Mauritian Manufacturers for the locally manufactured goods procured through this contract shall benefit from a Margin of Preference of 40% at evaluation.

SMEs not holding “Made in Moris” certification, whose local input in the locally manufactured goods procured through this contract accounts for at least 25 %, shall be eligible for a Margin of Preference of 30% at evaluation.

Local companies whose local input in the locally manufactured goods procured through this contract accounts for at least 25 % or bearing the ‘Made in Moris’ certification shall be eligible for a Margin of Preference of 30% at evaluation

Bidders applying for the Margin of Preference shall submit along with their bid, the following:

- (i) evidence of their registration as enterprise in the Republic of Mauritius;
- (ii) where applicable, evidence of registration with SME Mauritius Ltd.;
- (iii) A cost structure for the goods item manufactured locally as per the format contained in the bidding document (where applicable);
- (iv) Certification issued by the Association of Mauritian Manufacturers for the goods bearing the “Made in Moris” label (where applicable).

Section IV. Bidding Forms

Table of Forms

Bidder Information Form	39
Joint Venture Partner Information Form	40
Bid Submission Form	41
Bid Securing Declaration	44
Price Schedule Forms	45
Bill of Quantities	46
Summary of Bill of Quantity.....	48
Bid Security (Bank Guarantee)	49
Manufacturer’s Authorization	50
Cost Structure for Value Added Calculation per Product.....	51
Notes on Locally Manufactured Goods.....	52

Bidder Information Form

[The Bidder shall fill in this Form in accordance with the instructions indicated below. No alterations to its format shall be permitted and no substitutions shall be accepted.]

Date: *[insert date (as day, month and year) of Bid Submission]*
Procurement No.: *[insert reference number of bidding process]*

Page _____ of _____ pages

1. Bidder's Legal Name <i>[insert Bidder's legal name]</i>
2. In case of JV, legal name of each party: <i>[insert legal name of each party in JV]</i>
3. Bidder's actual or intended Country of Registration: <i>[insert actual or intended Country of Registration]</i>
4. Bidder's Year of Registration: <i>[insert Bidder's year of registration]</i>
5. Bidder's Legal Address in Country of Registration: <i>[insert Bidder's legal address in country of registration]</i>
6. Bidder's Authorized Representative Name: <i>[insert Authorized Representative's name]</i> Address: <i>[insert Authorized Representative's Address]</i> Telephone/Fax numbers: <i>[insert Authorized Representative's telephone/fax numbers]</i> Email Address: <i>[insert Authorized Representative's email address]</i>
7. Attached are copies of original documents of: <i>[check the box(es) of the attached original documents]</i> <input type="checkbox"/> Articles of Incorporation or Registration of firm named in 1, above, in accordance with ITB Sub-Clauses 5.1 and 5.2. <input type="checkbox"/> In case of JV, letter of intent to form JV or JV agreement, in accordance with ITB Sub-Clause 5.1. <input type="checkbox"/> In case of government owned entity from Mauritius, documents establishing legal and financial autonomy and compliance with commercial law, in accordance with ITB Sub-Clause 5.5.

Joint Venture Partner Information Form

[The Bidder shall fill in this Form in accordance with the instructions indicated below].

Date: *[insert date (as day, month and year) of Bid Submission]*

Procurement No.: *[insert reference number of bidding process]*

1. Bidder's Legal Name: <i>[insert Bidder's legal name]</i>
2. JV's Party legal name: <i>[insert JV's Party legal name]</i>
3. JV's Party Country of Registration: <i>[insert JV's Party country of registration]</i>
4. JV's Party Year of Registration: <i>[insert JV's Party year of registration]</i>
5. JV's Party Legal Address in Country of Registration: <i>[insert JV's Party legal address in country of registration]</i>
<p>6. JV's Party Authorized Representative</p> <p>Name: <i>[insert name of JV's Party authorized representative]</i></p> <p>Address: <i>[insert address of JV's Party authorized representative]</i></p> <p>Telephone/Fax numbers: <i>[insert telephone/fax numbers of JV's Party authorized representative]</i></p> <p>Email Address: <i>[insert email address of JV's Party authorized representative]</i></p>
<p>7. Attached are copies of original documents of: <i>[check the box(es) of the attached original documents]</i></p> <p><input type="checkbox"/> Articles of Incorporation or Registration of firm named in 2, above, in accordance with ITB Sub-Clauses 4.1 and 4.2.</p> <p><input type="checkbox"/> In case of government owned entity from Mauritius, documents establishing legal and financial autonomy and compliance with commercial law, in accordance with ITB Sub-Clause 5.5.</p>

Bid Submission Form

[The Bidder shall fill in this Form in accordance with the instructions indicated. No alterations to its format shall be permitted and no substitutions shall be accepted.]

Date: *[insert date (as day, month and year) of Bid Submission]*
Procurement Ref. No.: *[insert reference number of bidding process]*
Alternative No.: *[insert identification No if this is a Bid for an alternative]*

To: *[insert complete name of Purchaser]*

We, the undersigned, declare that:

- (a) We have examined and have no reservations to the Bidding Documents, including Addenda No.: _____ *[insert the number and issuing date of each Addendum];*
- (b) We offer to supply in conformity with the Bidding Documents and in accordance with the Delivery Schedules specified in the Schedule of Requirements the following Goods and Related Services _____ *[insert a brief description of the Goods and Related Services];*
- (c) The total price of our Bid, excluding any discounts offered in item (d) below, is: _____ *[insert the total bid price in words and figures, indicating the various amounts and the respective currencies];*
- (d) The discounts offered and the methodology for their application are:

Discounts. If our bid is accepted, the following discounts shall apply. _____ *[Specify in detail each discount offered and the specific item of the Schedule of Requirements to which it applies.]*

Methodology of Application of the Discounts. The discounts shall be applied using the following method: _____ *[Specify in detail the method that shall be used to apply the discounts];*

- (e) Our bid shall be valid for the period of time specified in ITB Sub-Clause 21.1, from the date fixed for the bid submission deadline in accordance with ITB Sub-Clause 25.1, and it shall remain binding upon us and may be accepted at any time before the expiration of that period;
- (f) If our bid is accepted, we undertake to obtain a Performance Security in accordance with ITB Clause 45 and GCC Clause 18 for the due performance of the Contract;
- (g) We, including any subcontractors or suppliers for any part of the contract, have nationality from eligible countries _____ *[insert the nationality of the Bidder,*

including that of all parties that comprise the Bidder, if the Bidder is a JV, and the nationality each subcontractor and supplier]

- (h) We have no conflict of interest in accordance with ITB Sub-Clause 5.2;
- (i) Our firm, its affiliates or subsidiaries—including any subcontractor or supplier for any part of the contract—have not been declared ineligible by an international financing agency such as the World Bank, African Development Bank or any other international agency or under the Laws of Mauritius or official regulations in accordance with ITB Sub-Clause 5.3;
- (j) I/We declare that I/We **“qualify/do not qualify”** for Margin of Preference as per Table below, and has submitted documentary evidence in this respect.

Description of Bidder	Applicable preference	Margin of	Bidder to tick as appropriate
Small and medium Enterprise bearing the ‘Made in Moris’ certification for the locally manufactured goods proposed		40%	
Small and medium Enterprise proposing locally manufactured goods		30%	
Local companies proposing locally manufactured goods		20%	

- (k) The following commissions, gratuities, or fees have been paid or are to be paid with respect to the bidding process or execution of the Contract: *[insert complete name of each Recipient, its full address, the reason for which each commission or gratuity was paid is payable and the amount and currency of each such commission or gratuity]*

Name of Recipient	Address	Reason	Amount
_____	_____	_____	_____
_____	_____	_____	_____
_____	_____	_____	_____
_____	_____	_____	_____

(If none has been paid or is to be paid, indicate “none.”)

- (l) We hereby confirm that we have read and understood the content of the Bid Securing Declaration attached herewith and subscribe fully to the terms and conditions contained therein, if required. We understand that non-compliance to the conditions mentioned may lead to disqualification.

- (m) We have taken steps to ensure that no person acting for us or on our behalf will engage in any type of fraud and corruption as per the principles described hereunder, during the bidding process and contract execution:
- i. We shall not, directly or through any other person or firm, offer, promise or give to any of the Purchaser's employees involved in the bidding process or the execution of the contract or to any third person any material or immaterial benefit which he/she is not legally entitled to, in order to obtain in exchange any advantage of any kind whatsoever during the tender process or during the execution of the contract.
 - ii. We shall not enter with other Bidders into any undisclosed agreement or understanding, whether formal or informal. This applies in particular to prices, specifications, certifications, subsidiary contracts, submission or non-submission of bids or any other actions to restrict competitiveness or to introduce cartelisation in the bidding process.
 - iii. We shall not use falsified documents, erroneous data or deliberately not disclose requested facts to obtain a benefit in a procurement proceeding.

We understand that transgression of the above is a serious offence and appropriate actions will be taken against such bidders.

- (n) We understand that this bid, together with your written acceptance, shall constitute a binding contract between us, until a formal contract is prepared and executed.
- (o) We understand that you are not bound to accept the lowest evaluated bid or any other bid that you may receive.

Signed: _____ *[insert signature of person whose name and capacity are shown]*
In the capacity of _____ *[insert legal capacity of person signing the Bid Submission Form]*

Name: _____ *[insert complete name of person signing the Bid Submission Form]*

Duly authorized to sign the bid for and on behalf of: _____ *[insert complete name of Bidder]*

Dated on _____ day of _____, _____ *[insert date of signing]*

Appendix to Bid Submission Form

Bid Securing Declaration

By subscribing to the undertaking in respect of paragraph (l) of the Bid Submission Form:

I/We* accept that I/we* may be disqualified from bidding for any contract with any Public Body for the period of time that may be determined by the Procurement Policy Office under section 35 of the Public Procurement Act, if I am/we are* in breach of any obligation under the bid conditions, because I/we*:

- (a) have modified or withdrawn my/our* Bid after the deadline for submission of bids during the period of bid validity specified by the Bidder in the Bid Submission Form; or
- (b) have refused to accept a correction of an error appearing on the face of the Bid; or
- (c) having been notified of the acceptance of our Bid by the (*insert name of public body*) during the period of bid validity, (i) have failed or refused to execute the Contract, if required, or (ii) have failed or refused to furnish the Performance Security, in accordance with the Instructions to Bidders.

I/We* understand this Bid Securing Declaration shall cease to be valid (a) in case I/we am/are the successful bidder, upon our receipt of copies of the contract signed by you and the Performance Security issued to you by me/us ; or (b) if I am/we are* not the successful Bidder, upon the earlier of (i) the receipt of your notification of the name of the successful Bidder; or (ii) thirty days after the expiration of the validity of my/our* Bid.

In case of a Joint Venture, all the partners of the Joint Venture shall be jointly and severally liable.

Price Schedule Forms

Bidder is requested to price the items as per the Bill of Quantities. The purchaser reserves the right to award the contract item wise basis with respect to any bill. The Purchaser may increase the quantity of any item listed in the Bill of Quantities by 10%.

SECTION IV: PRICE ACTIVITY SCHEDULE
Procurement Reference number: OMD/ SPAREPARTS/07/23

Bill of Quantities
Bill No 1

Supply of Spare Parts

Item No	Description	Unit	Qty	Rate (MUR)	Amount (MUR)
1.1	Resilient seat Gate valve DN150 PN16 with valve cap, bolts, nuts and gaskets.	No.	25		
1.1(a)	Supply of wheel opener for item 1.1	No.	5		
1.2	Flexible Coupling PN16 in the range 192-209 or 193-210. Bidder to specify	No.	10		
1.2(a)	Flexible Coupling PN16 in the range 133 - 157	No.	4		
1.2(b)	Flexible Coupling PN16 in the range 218 - 235	No.	4		
1.3	Complete Sprinkler Gun giving a flow of 22.5 l/s \pm 4 l/s at a nozzle pressure of 600 kpa \pm 50 for a throw in the range of 55-65m	No.	2		
1.3(a)	Complete Sprinkler Gun giving a flow of 40 l/s \pm 2 l/s at a nozzle pressure of 600 kpa \pm 100 for a throw in the range of 70 \pm 3m.	No.	2		
1.3(b)	Complete Sprinkler Gun giving a flow of 44.2 l/s \pm 4 l/s at a nozzle pressure of 600 kpa \pm 100 with a wetted diameter of 150m \pm 2 under windless condition.	No.	5		
1.3(c)	Complete Sprinkler Gun giving a flow in the range of 5 l/s to 7 l/s at a nozzle pressure of 250 kpa \pm 50 with a radius in the range of 25 to 32m under windless condition.	No.	2		
1.3(d)	Complete Sprinkler Gun giving a flow in the range of 3.0 to 5 l/s at a nozzle pressure of 200 kpa \pm 50 with a radius in the range of 20 to 25m under windless condition.	No.	2		
1.4	Shift Lever assembly – 10226-004 and will include P No. 6598(2), 6600, 10180, 10202, 10214 for Nelson sprinkler	Set	1		
1.5	Drive Arm assembly – 10228-001 and which will include P No. 6060(2), 8270, 6818(3), 10612, 10608, 8904 for Nelson sprinkler	Set	1		
1.6	Drive Vane of Sprinkler Gun SR200 or its equivalent	No.	10		

1.7	HK male Coupler 3 ½” mounting on DN 150 flange with flange drilled to PN 16 (Refer Annex A) inclusive of bolts, nuts and gaskets.	No.	20		
1.8	HK male flanged Coupler 6” mounting on DN 150 with flange drilled to PN 16 (Refer Annex B) inclusive of bolts, nuts and gaskets.	No.	40		
1.9	Resilient seat Gate valve DN250 PN16 with valve cap inclusive of bolts, nuts and gaskets.	No.	5		
1.9(a)	Supply of wheel opener for item 1.9	No.	5		
	TOTAL C/F TO SUMMARY OF BILLS				

Note:

- a) Flange male couplers shall be as per annexed drawings and flanges drilled to PN 16

Supply of Spare Parts

Procurement Reference Number: OMD/ SPAREPARTS/07/23

SUMMARY OF BILL OF QUANTITY

Item No	Description	Bill No	Amount (MUR)
1	Supply of Fittings for Pipeline and Hydrant assembly	1	
2	Inspection test carried out locally upon instruction from the Purchaser (Provisional)		50,000
3	Contingency		150,000
4	Sub-total		
5	Add 15% VAT		
6	Grand Total to be transferred to the Bid Submission Form		

NAME:

POSITION:

SIGNATURE:.....

DATE:.....

NAME OF COMPANY:.....

ADDRESS OF COMPANY:.....

.....

The price is fixed and is not subject to change due to fluctuation in rate of exchange.

Bid Security (Bank/Insurance Guarantee)
(NOT APPLICABLE)

.....[Bank/Insurance company's Name and Address of issuing Branch or Office]

Beneficiary:.....[Name and Address of Public Body].....

Date:

BID GUARANTEE No.:

We have been informed that[name of the Bidder]..... (hereinafter called "the Bidder") has submitted to you its bid dated(hereinafter called "the Bid") for the execution of[name of contract] under Invitation for Bids No.....[IFB number] ("the IFB").

Furthermore, we understand that, according to your conditions, bids must be supported by a Bid Security.

At the request of the Bidder, we[name of Bank/Insurance company]..... hereby irrevocably undertake to pay you any sum or sums not exceeding in total an amount of[amount in figures]..... (.....amount in words.....) upon receipt by us of your first demand in writing accompanied by a written statement stating that the Bidder is in breach of its obligation(s) under the bid conditions, because the Bidder:

- (a) has modified or withdrawn its Bid after the deadline for submission of its bid during the period of bid validity specified by the Bidder in the Form of Bid; or
- (b) has refused to accept a correction of an error appearing on the face of the Bid; or
- (c) having been notified of the acceptance of its Bid by the Public Body during the period of bid validity, (i) has failed or refused to sign the contract Form, if required, or (ii) has failed or refused to furnish the Performance Security, in accordance with the Instructions to Bidders.

This guarantee shall expire: (a) if the Bidder is the successful bidder, upon our receipt of copies of the contract signed by the Bidder and the Performance Security issued to you upon the instruction of the Bidder; or (b) if the Bidder is not the successful bidder, upon the earlier of (i) our receipt of a copy of your notification to the Bidder of the name of the successful bidder; or (ii) thirty days after the expiration of the Bidder's Bid.

Consequently, any demand for payment under this guarantee must be received by us at the office on or before[Public Body to insert date].....

This Guarantee is subject to the Uniform Rules for Demand Guarantees, ICC Publication No. 458. (Applicable to overseas bidders only).

.....[Bank/Insurance company's seal and authorized signature(s)].....

Manufacturer's Authorization (NOT APPLICABLE)

*[The Bidder shall require the Manufacturer to fill in this Form in accordance with the instructions indicated. This letter of authorization should be on the letterhead of the Manufacturer and should be signed by a person with the proper authority to sign documents that are binding on the Manufacturer. The Bidder shall include it in its bid, if so indicated in the **BDS**.]*

Date: *[insert date (as day, month and year) of Bid Submission]*
Procurement Ref. No.: *[insert number of bidding process]*
Alternative No.: *[insert identification No if this is a Bid for an alternative]*

To: *[insert complete name of Purchaser]*

WHEREAS

We *[insert complete name of Manufacturer]*, who are official manufacturers of *[insert type of goods manufactured]*, having factories at *[insert full address of Manufacturer's factories]*, do hereby authorize *[insert complete name of Bidder]* to submit a bid the purpose of which is to provide the following Goods, manufactured by us *[insert name and or brief description of the Goods]*, and to subsequently negotiate and sign the Contract.

We hereby extend our full guarantee and warranty in accordance with Clause 28 of the General Conditions of Contract, with respect to the Goods offered by the above firm.

Signed: *[insert signature(s) of authorized representative(s) of the Manufacturer]*

Name: *[insert complete name(s) of authorized representative(s) of the Manufacturer]*

Title: *[insert title]*

Dated on _____ day of _____, _____ *[insert date of signing]*

COST STRUCTURE FOR VALUE ADDED CALCULATION PER PRODUCT
(NOT APPLICABLE)

COST STRUCTURE FOR VALUE ADDED CALCULATION PER PRODUCT		
	Rs	Rs
Raw Materials, Accessories & Components		
• Imported (CIF)
• Local
Labour Cost		
• Direct Labour
Direct Factory Expenses		
• Operating Cost of Machine
• Expenses related for finishing of goods
• Packaging costs		
Cost of Factory Overheads		
• Electricity
• Rates & Insurance		
• Telephone
• Rent
• Depreciation
• Interest on Loans
• Direct Consumables
• Indirect Labour Charges (factory employees)		
Other (please specify)		
•
•
•
TOTAL COST		

Local Value Added = $\frac{\text{Total Cost} - \text{Cost of imported inputs}}{\text{Total Cost}} \times 100$

- The cost structure should be certified by a Certified Accountant

Notes on Locally manufactured goods

Locally Manufactured Goods -Value-added criterion

The goods have been produced in Mauritius wholly or partially from imported materials (or materials of unknown origin) and the value added resulting from the process of production accounts for at least 25% of the ex-factory cost of the finished product.

Explanation:

The value added is the difference between the ex-factory cost of the finished product and the c.i.f. value of imported materials used in production.

Ex-factory cost means the value of the total inputs required to produce a given product. In applying this criterion, domestic material content may be either low or non-existent in the composition of the products.

Calculation of ex-factory cost:

The following costs, charges and expenses should be included:

(a) The cost of imported materials, as represented by their c.i.f. value accepted by the Customs authorities on clearance for home consumption, or on temporary admission at the time of last importation in Mauritius where they were used in a process of production, less the amount of any transport costs incurred in transit.

Provided that the cost of imported materials not imported by the manufacturer will be the delivery cost at the factory but excluding customs duties and other charges of equivalent effect thereon;

(b) The cost of **local materials**, as represented by their delivery price at the factory;

(c) The cost of **direct labour** as represented by the wages paid to the operatives responsible for the manufacture of the goods;

(d) The cost of direct factory expenses, as represented by:

- the operating cost of the machine being used to manufacture the goods;
- the expenses incurred in the cleaning, drying, polishing, pressing or any other process, as may be necessary for the finishing of the goods;
- the cost of putting up the goods in their retail packages and the cost of such packages but excluding any extra cost of packing the goods for transportation and the cost of any extra packages;
- the cost of special designs, drawings or layout; and the hire of tools, or equipment for the production of the goods.

(e) The cost of **factory overheads** as represented by:

- rent, rates and insurance charges directly attributed to the factory;
- indirect labour charges, including salaries paid to factory managers, wages paid to foremen, examiners and testers of the goods;
- power, light, water and other service charges directly attributed to the cost of manufacture of the goods;
- consumable stores, including minor tools, grease, oil and other incidental items and materials used in the manufacture of the goods;
- depreciation and maintenance of factory buildings, plant and machinery, tools and other items used in the manufacture of the goods

The following costs, charges and expenses **should be excluded**:

(a) **Administration expenses** as represented by:

- office expenses, office rent and salaries paid to accountants, clerks, managers and other executive personnel;
- directors' fees, other than salaries paid to directors who act in the capacity of factory managers;
- statistical and costing expenses in respect of the manufactured goods;
- investigation and experimental expenses.

(b) **Selling expenses**, as represented by:

- the cost of soliciting and securing orders, including such expenses as advertising charges and agents' or salesmen' commission or salaries;
- expenses incurred in the making of designs, estimates and tenders.

(c) **Distribution expenses**, represented by all the expenditure incurred after goods have left the factory, including;

- the cost of any materials and payments of wages incurred in the packaging of the goods for export;
- warehousing expenses incurred in the storage of the finished goods;
- the cost of transporting the goods to their destination.

(d) **Charges not directly attributed to the manufacture of the goods**:

- any customs duty and other charges of equivalent effect paid on the imported raw materials;
- any excise duty paid on raw materials produced in the country where the finished goods are manufactured;
- any other indirect taxes paid on the manufactured products;
- any royalties paid in respect of patents, special machinery or designs; and
- finance charges related to working capital.

PART 2 – Supply Requirements

Section V. Schedule of Requirements

Contents

Specifications	56
Drawings	59
Inspections and Tests.....	60

3. Specifications

Bill No 1- Supply of Spare Parts

Gate Valves

Unless otherwise specified the gate valves shall be double flanged and manufactured in accordance with AFNOR NF E 29-423, E 29-425 and E 29-426 or to BS EN 1171 or BS 5163 or ISO 9001 other standard to the approval of the Employer's or the Project Manager and wedge shall be of cast iron. All valves shall have a drain plug, and easing screws shall be fitted on all sizes above 200 mm nominal diameter. All valves shall be provided if required with approved fittings to enable their operation under a maximum differential pressure of 16 bar.

The valves shall have inside screw spindles and shall close either clockwise or anticlockwise. The spindle shall be shouldered to allow repacking of the gland whilst the pipeline remains in service.

The spindle shall be made of stainless steel at least equivalent to X20Cr13. The wedge gate shall be solid and the wedge facing rings and body seats shall be made of stainless steel or alternatively of bronze or gun metal.

The surface boxes, protection sheaths and extension spindles shall be protected from corrosion by a 150 micron coating of bitumen epoxy.

The Bidder shall submit along with its bid the manufacturer's certificate which shall show that the valves and their components comply with the above specified requirements.

The minimum nominal pressure rating shall be PN 16 or higher as specified by the manufacturer and flanges and drilling shall be BS 4504.

Other norms or standards may be accepted but Bidder should substantiate its equivalence.

Galvanised Flanged male Couplers for Hydrant Assembly

The flange couplers shall not exceed the overall height specified and shall withstand a pressure not exceeding 16 bars

The flanged coupler 3^{1/2}" shall be mounted on a flange of DN 150 and the coupler shall suit a female coupler of diameter 3^{1/2}". The overall height shall be in the range of 330 mm ± 20. Refer to drawing annexed.

The flange male coupler 6" shall be mounted on a flange of 150 DN. The overall height shall be in the range of 330 mm ± 20 and flanges drilled to PN 16.

Note: The Bidder shall ensure that the one they are proposing shall meet the existing female adapters that are being used at the Irrigation Authority. Bidders are requested to see the one

actually being used and take note of any dimension they may found to be appropriate to ensure compatibility.

Flexible Couplings

The flexible range coupling shall withstand a pressure of 16 bars. Other range may be accepted by the Public Body provided it will meet the respective range of diameter of PVC or Ductile Iron pipe and Asbestos Cement pipes.

Flexible couplings and flange adaptors exposed in chambers shall be protected internally and externally with an approved nylon or epoxy coating to minimum thickness 250 microns. Bolts and nuts shall have similar coating or be in stainless steel to BS 970 Grade 316 S16. Buried couplings shall be protected by approved molten bitumen moulding or paste and tape wrappings.

The flexible Coupling shall have the following particulars:

S.n	Description	Specification
1	Material	Ductile Iron/ Cast Iron
2	Maximum working Pressure	16 Bars
3	Setting gap	19 mm
4	Angular deflection	3 - 6 Degrees
5	Axial movement	0 -5 mm
6	Bolts and Nuts	Hot Dipped Galvanised
7	Coating	Epoxy (Blue)
8	Rubber Gasket	EPDM Rubber
9	Sizes	Refer to BOQ

SPRINKLERS

General

The sprinklers shall consist of a big-gun flanged to a male hydrant coupler. These two pieces form one portable system that shall be connected easily to the female hydrant coupler fixed to the solid-set pipe network.

Sprinkler Gun

The gun shall be a rotating gun with a barrel inclined at an adjustable angle of 16° to 28° with the horizontal. The gun shall have either a tapered bore or a ring orifice nozzle capable of discharging a flow of 44.2 l/s \pm 4 at a nozzle pressure of 600 kpa \pm 100 kpa, with a minimum wetted diameter of 150 m \pm 2 under windless condition. A small compensation jet can be used to improve the distribution curve close to the sprinkler, provided that the total flow rate at both nozzles does not exceed 44.2 l/s \pm 4 at a nozzle pressure of 600 kpa.

Sprinkler Gun

The gun shall be a rotating gun with a fixed barrel trajectory at an adjustable angle of either 24° or 25° or 26° or 27°) with the horizontal. The gun shall have either a tapered bore or a ring orifice nozzle capable of discharging a flow of 22.5 l/s \pm 2 at a nozzle pressure of 600 kpa \pm 50 kpa. The throw shall be in the range of 55 to 65m for both part and full circle.

Sprinkler Gun

The gun shall be a rotating gun with a fixed barrel trajectory at an adjustable angle of either 24° or 25° or 26° or 27°) with the horizontal. The gun shall have either a tapered bore or a ring orifice nozzle capable of discharging a flow of 40 l/s \pm 2 at a nozzle pressure of 600 kpa \pm 100 kpa. The throw shall be 70 \pm 3 m for both part and full circle. The total weight shall be in the range of 25 to 30 kg or lesser and the gun must be able to be mounted on a 150mm ND hydrant.

Sprinkler Gun – (for Centre Pivot)

The gun shall be a rotating gun with a fixed barrel trajectory at an adjustable angle of either 24° or 25° or 26° or 27°) with the horizontal. The gun shall have either a tapered bore or a ring orifice nozzle capable of discharging a flow of 5 l/s to 7 l/s at a nozzle pressure of 250 kpa \pm 50 kpa with a radius in the range of 25 to 32m under windless condition.

Sprinkler Gun – (for Centre Pivot)

The gun shall be a rotating gun with a fixed barrel trajectory at an adjustable angle of either 24° or 25° or 26° or 27°) with the horizontal. The gun shall have either a tapered bore or a ring orifice nozzle capable of discharging a flow in the range of 3 l/s to 5 l/s at a nozzle pressure of 200 kpa \pm 50 kpa with a radius in the range of 20 to 25m under windless condition.

Origin of Materials

The Bidder may be requested to submit appropriate document indicating the origin of goods being proposed and to be supported by a certificate of origin by an approved Chamber of Commerce or approved body in the country where the proposed goods are being manufactured. The test carried out by the manufacturer of the supplier is to be submitted by the bidder for relevant items quoted by the bidder in the Bill of Quantities.

Right of the Public Body

The Irrigation Authority reserves the right to increase or decrease the quantities of any item to be ordered by the time of finalising the order list due to the requirement if found necessary.

All items are to be priced based on sea freight.

4. Drawings

These Bidding Documents include *the following* drawings.

List of Drawings		
Drawing Nr.	Drawing Name	Purpose
ANNEX A	HK Male Coupler 3½"	To ensure compatibility with actual one being used.
ANNEX B	HK Male Coupler 6"	To ensure compatibility with actual one being used.
ANNEX C	SR200 BIG GUN- Part List	
ANNEX D	SR200 BIG GUN- Part List	
ANNEX E	SR200 BIG GUN- Part List	
ANNEX F	SR200 BIG GUN- Part List	

5. Inspections and Tests

The bidder may be requested to provide test certificate carried out by the manufacturer for the following items:

- 1) Sprinklers
- 2) Gate valve withstand a pressure of 16 bars.
- 3) Male couplers

The Irrigation Authority reserves the right to carry out further tests from local authority.

PART 3 - Contract

Section VI. General Conditions of Contract

The General Conditions of Contract (GCC) applicable for this procurement is available on the web site of the Procurement Policy Office ppo.govmu.org under Reference: **G/RFQ-GCC4/11-21**

Section VII. Special Conditions of Contract

The following Special Conditions of Contract (SCC) shall supplement and / or amend the General Conditions of Contract (GCC). Whenever there is a conflict, the provisions herein shall prevail over those in the GCC.

GCC 1.1e)	The Supplier shall deliver the goods within 90 calendar days after receipt of Letter of Acceptance from the Purchaser
GCC 1.1(h)	The Purchaser is: The Irrigation Authority
GCC 1.1 (m)	The final destination for delivery of the Goods will be partly at our main store at Plaine des Papayes or Solitude and the remaining part at our store at Palmar . The Purchaser will determine at which store the items shall be delivered.
GCC 4.2 (a)	Not Applicable
GCC 4.2 (b)	The version edition of Incoterms shall be Incoterms 2020.
GCC 8.1	For <u>notices</u> , the Purchaser's address shall be: <p style="text-align: center;">The General Manager Irrigation Authority 5th Floor, Fon Sing Building 12 Edith Cavell Street, Port Louis, Republic of Mauritius Tel: 210 6596 Fax: 212 7652 Email: irrig@irrig.org</p>
GCC 10.2	The rules of procedure for arbitration proceedings pursuant to GCC Clause 10.2 shall be either adjudication or arbitration or decided by the local supplier or purchaser to settle the dispute in accordance with the Laws of Mauritius.
GCC 13.1	Not Applicable
GCC 15.1	The prices charged for the Goods supplied and the related Services performed shall not be adjustable.
GCC 16.1	The method and conditions of payment to be made to the Supplier under this Contract shall be as follows:

	<p>(a) No advance payment shall be made.</p> <p>(b) Payment shall be made promptly by the purchaser, but in no case later than 30 days after submission of an invoice or request for payment by the supplier and after the purchaser has accepted it in writing.</p>
GCC 16.4 (b)	Local Suppliers shall be paid in Mauritian Rupees only. The prices shall not be adjustable to fluctuation in the rate of exchange.
GCC 16.5	Interest shall be payable immediately after the due date for payment. The interest rate shall be the legal rate.
GCC 18.1	A Performance Security shall not be required.
GCC 18.3	The Performance Security shall be denominated in the currencies of payment of the Contract, in accordance with their portions of the Contract Price (exclusive of VAT). Not Applicable
GCC 18.4	Discharge of the Performance Security shall take: Not Applicable
GCC 23.2	The packing, marking and documentation within and outside the packages shall not be required.
GCC 24.1	The insurance coverage shall be as specified in the Incoterms.
GCC 25.1	Responsibility for transportation of the Goods shall be as specified in the Incoterms and shall rest on the local supplier.
GCC 26.1	The inspections and tests shall be decided by the Project Manager/ Engineer responsible for managing the contract.
GCC 26.2	The Inspections and tests may be conducted at Mauritius Standard Bureau (MSB) or any local laboratory decided by the Project Manager
GCC 27.1	The liquidated damages shall be MUR 2,000.00 per calendar day
GCC 27.1	The maximum amount of liquidated damages shall be 10% of the Awarded Contract Value.
GCC 28.3	For all items, the minimum period of warranty shall be 12 months for any of the goods being accepted from a Bidder.
GCC 28.5	The period for repair or replacement shall be in maximum 15 calendar days if effected locally or 90 days for goods that require to be imported again.

Attachment: Price Adjustment Formula (Not Applicable)

If in accordance with GCC 15.2, prices shall be adjustable, the following method shall be used to calculate the price adjustment:

- 15.2 Prices payable to the Supplier, as stated in the Contract, shall be subject to adjustment during performance of the Contract to reflect changes in the cost of labor and material components in accordance with the formula:

$$P_1 = P_0 \left[a + \frac{bL_1}{L_0} + \frac{cM_1}{M_0} \right] - P_0$$

$$a+b+c = 1$$

in which:

- P_1 = adjustment amount payable to the Supplier.
 P_0 = Contract Price (base price).
 a = fixed element representing profits and overheads included in the Contract Price and generally in the range of five (5) to fifteen (15) percent.
 b = estimated percentage of labor component in the Contract Price.
 c = estimated percentage of material component in the Contract Price.
 L_0, L_1 = labor indices applicable to the appropriate industry in the country of origin on the base date and date for adjustment, respectively.
 M_0, M_1 = material indices for the major raw material on the base date and date for adjustment, respectively, in the country of origin.

The coefficients a, b, and c as specified by the Purchaser are as follows:

- $a = [insert\ value\ of\ coefficient]$
 $b = [insert\ value\ of\ coefficient]$
 $c = [insert\ value\ of\ coefficient]$

The Bidder shall indicate the source of the indices and the base date indices in its bid.

Base date = thirty (30) days prior to the deadline for submission of the bids.

Date of adjustment = $[insert\ number\ of\ weeks]$ weeks prior to date of shipment (representing the mid-point of the period of manufacture).

The above price adjustment formula shall be invoked by either party subject to the following further conditions:

- (a) No price adjustment shall be allowed beyond the original delivery dates unless specifically stated in the extension letter. As a rule, no price adjustment shall be allowed for periods of delay for which the Supplier is entirely responsible. The

- Purchaser will, however, be entitled to any decrease in the prices of the Goods and Services subject to adjustment.
- (b) If the currency in which the Contract Price P_0 is expressed is different from the currency of origin of the labor and material indices, a correction factor will be applied to avoid incorrect adjustments of the Contract Price. The correction factor shall correspond to the ratio of exchange rates between the two currencies on the base date and the date for adjustment as defined above.
 - (c) No price adjustment shall be payable on the portion of the Contract Price paid to the Supplier as advance payment.

Section VIII. Contract Forms

Table of Forms

1. Contract Agreement	68
2. Performance Security	70
3. Bank/Insurance Guarantee for Advance Payment.....	72

1. Contract Agreement

[The successful Bidder shall fill in this form in accordance with the instructions indicated]

THIS CONTRACT AGREEMENT is made

the *[insert: **number**]* day of *[insert: **month**], [insert: **year**]*.

BETWEEN

- (1) *[insert complete name of Purchaser], a [insert description of type of legal entity, for example, an agency of the Ministry of of the Government of { Mauritius }, or company incorporated under the laws of {Mauritius}] and having its principal place of business at [insert address of Purchaser] (hereinafter called “the Purchaser”), and*
- (2) *[insert name of Supplier], a company incorporated under the laws of [insert: country of Supplier] and having its principal place of business at [insert: address of Supplier] (hereinafter called “the Supplier”).*

WHEREAS the Purchaser invited bids for certain Goods and related services, viz., *[insert brief description of Goods and Services]* and has accepted a Bid by the Supplier for the supply of those Goods and Services in the sum of *[insert Contract Price in words and figures, expressed in the Contract currency(ies)]* (hereinafter called “the Contract Price”).

NOW THIS AGREEMENT WITNESSETH AS FOLLOWS:

1. In this Agreement, words and expressions shall have the same meanings as are respectively assigned to them in the Conditions of Contract referred to.
2. The following documents shall constitute the Contract between the Purchaser and the Supplier, and each shall be read and construed as an integral part of the Contract:
 - (a) This Contract Agreement
 - (b) Special Conditions of Contract
 - (c) General Conditions of Contract
 - (d) Technical Requirements (including Schedule of Requirements and Technical Specifications)
 - (e) The Supplier’s Bid and original Price Schedules
 - (f) The Purchaser’s Notification of Award
 - (g) *[Add here any other document(s)]*

3. This Contract shall prevail over all other Contract documents. In the event of any discrepancy or inconsistency within the Contract documents, then the documents shall prevail in the order listed above.
4. In consideration of the payments to be made by the Purchaser to the Supplier as hereinafter mentioned, the Supplier hereby covenants with the Purchaser to provide the Goods and Services and to remedy defects therein in conformity in all respects with the provisions of the Contract.
5. The Purchaser hereby covenants to pay the Supplier in consideration of the provision of the Goods and Services and the remedying of defects therein, the Contract Price or such other sum as may become payable under the provisions of the Contract at the times and in the manner prescribed by the Contract.

IN WITNESS whereof the parties hereto have caused this Agreement to be executed in accordance with the laws of Mauritius on the day, month and year indicated above.

For and on behalf of the Purchaser

Signed: *[insert signature]*
in the capacity of *[insert title or other appropriate designation]*
in the presence of *[insert identification of official witness]*

For and on behalf of the Supplier

Signed: *[insert signature of authorized representative(s) of the Supplier]*
in the capacity of *[insert title or other appropriate designation]*
in the presence of *[insert identification of official witness]*

2. Performance Security

[The bank/Insurance company, as requested by the successful Bidder, shall fill in this form in accordance with the instructions indicated]

Date: *[insert date (as day, month, and year) of Bid Submission]*
Procurement Reference No. and title: *[insert no. and title of bidding process]*

Bank/Insurance company's Branch or Office: *[insert complete name of Guarantor]*

Beneficiary: *[insert complete name of Purchaser]*

PERFORMANCE GUARANTEE No.: *[insert Performance Guarantee number]*

We have been informed that *[insert complete name of Supplier]* (hereinafter called "the Supplier") has entered into Contract No. *[insert number]* dated *[insert day and month]*, *[insert year]* with you, for the supply of *[description of Goods and related Services]* (hereinafter called "the Contract").

Furthermore, we understand that, according to the conditions of the Contract, a Performance Guarantee is required.

At the request of the Supplier, we hereby irrevocably undertake to pay you any sum(s) not exceeding *[insert amount(s)⁶ in figures and words]* upon receipt by us of your first demand in writing declaring the Supplier to be in default under the Contract, without cavil or argument, or your needing to prove or to show grounds or reasons for your demand or the sum specified therein.

This Guarantee shall expire no later than the *[insert number]* day of *[insert month]* *[insert year]*,⁷ and any demand for payment under it must be received by us at this office on or before that date.

This guarantee is subject to the Uniform Rules for Demand Guarantees, ICC Publication No. 758.

⁶ *The Bank/Insurance company shall insert the amount(s) specified in the SCC and denominated, as specified in the SCC, either in the currency(ies) of the Contract or a freely convertible currency acceptable to the Purchaser.*

⁷ *Dates established in accordance with Clause 18.4 of the General Conditions of Contract ("GCC"), taking into account any warranty obligations of the Supplier under Clause 16.2 of the GCC intended to be secured by a partial Performance Guarantee. The Purchaser should note that in the event of an extension of the time to perform the Contract, the Purchaser would need to request an extension of this Guarantee from the Bank/Insurance company. Such request must be in writing and must be made prior to the expiration date established in the Guarantee. In preparing this Guarantee, the Purchaser might consider adding the following text to the Form, at the end of the penultimate paragraph: "We agree to a one-time extension of this Guarantee for a period not to exceed [six months] [one year], in response to the Purchaser's written request for such extension, such request to be presented to us before the expiry of the Guarantee."*

[signatures of authorized representatives of the bank/Insurance company and the Supplier]

1. Bank/Insurance Guarantee for Advance Payment (NOT APPLICABLE)

[The bank/Insurance company, as requested by the successful Bidder, shall fill in this form in accordance with the instructions indicated.]

Date: *[insert date (as day, month, and year) of Bid Submission]*
Procurement No. and title: *[insert number and title of bidding process]*

[bank's letterhead]

Beneficiary: *[insert legal name and address of Purchaser]*

ADVANCE PAYMENT GUARANTEE No.: *[insert Advance Payment Guarantee no.]*

We, *[insert legal name and address of bank/Insurance company]*, have been informed that *[insert complete name and address of Supplier]* (hereinafter called "the Supplier") has entered into contract with you - Contract No. *[insert number]* dated *[insert date of Agreement]* - for the supply of *[insert types of Goods to be delivered]* (hereinafter called "the Contract").

Furthermore, we understand that, according to the conditions of the Contract, an advance is to be made against an advance payment guarantee.

At the request of the Supplier, we hereby irrevocably undertake to pay you any sum or sums not exceeding in total an amount of *[insert amount(s)⁸ in figures and words]* upon receipt by us of your first demand in writing declaring that the Supplier is in breach of its obligation under the Contract because the Supplier used the advance payment for purposes other than toward delivery of the Goods.

It is a condition for any claim and payment under this Guarantee to be made that the advance payment referred to above must have been received by the Supplier on its account *[insert number and domicile of the account]*

This Guarantee shall remain valid and in full effect from the date of the advance payment received by the Supplier under the Contract until *[insert date⁹]*.

⁸ *The bank/Insurance company shall insert the amount(s) specified in the SCC and denominated, as specified in the SCC, either in the currency(ies) of the Contract or a freely convertible currency acceptable to the Purchaser.*

⁹ *Insert the Delivery date stipulated in the Contract Delivery Schedule. The Purchaser should note that in the event of an extension of the time to perform the Contract, the Purchaser would need to request an extension of this Guarantee from the bank/Insurance company. Such request must be in writing and must be made prior to the expiration date established in the Guarantee. In preparing this Guarantee, the Purchaser might consider adding the following text to the Form, at the end of the penultimate paragraph: "We agree to a one-time extension of this Guarantee for a period not to exceed [six months][one year], in response to the Purchaser's written request for such extension, such request to be presented to us before the expiry of the Guarantee."*

This Guarantee is subject to the Uniform Rules for Demand Guarantees, ICC Publication No. 758.

[signature(s) of authorized representative(s) of the bank/Insurance company]

SPECIFICATIONS FOR COUPLING

“HK Coupler – Male Coupler 3 ½” Including Hook and Flap mounting on DN 150. Flange drilled to PN 10 (8 holes)”, the coupling should be equal or equivalent to Bauer-Type as specified below :

Dimension		a/mm	DN(flange)
HK	inch	250	150/6” (Drilled to PN 10 -8 holes)
89	3 ½		

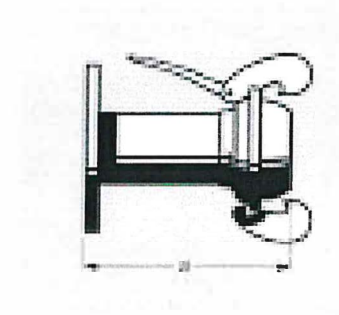

The coupling should be galvanised according to DIN EN ISO 1461

SPECIFICATIONS FOR COUPLING

Quick Coupler – Male Coupler 6” including Hook and Flap mounting on flange DN 150 drilled to PN 16 (8 holes). The flanged connection can be of make Bauer or an equivalent to Bauer type as specified below:

Diameter of inlet pipe		a/mm	Flange
mm	inch	Around 330	PN 16
150	6		

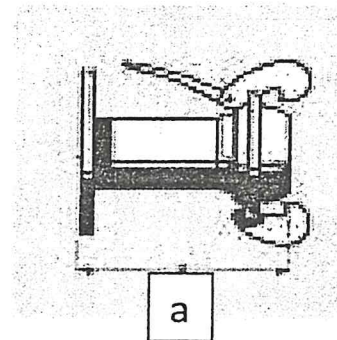

A minimum of 50 mm clearance is to be observed when the handle/flap is in touch with the vertical riser after lowering the longer hook for fixing of the female coupler.

The coupling should be galvanized according to DIN 50976 or equivalent on any other international standard shall be accepted.



SR200 BIG GUN®

SR200 BIG GUN® PARTS LIST

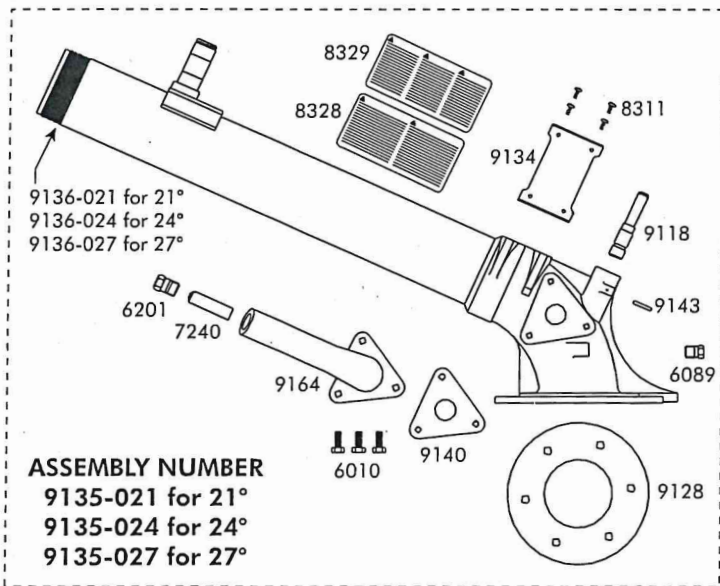
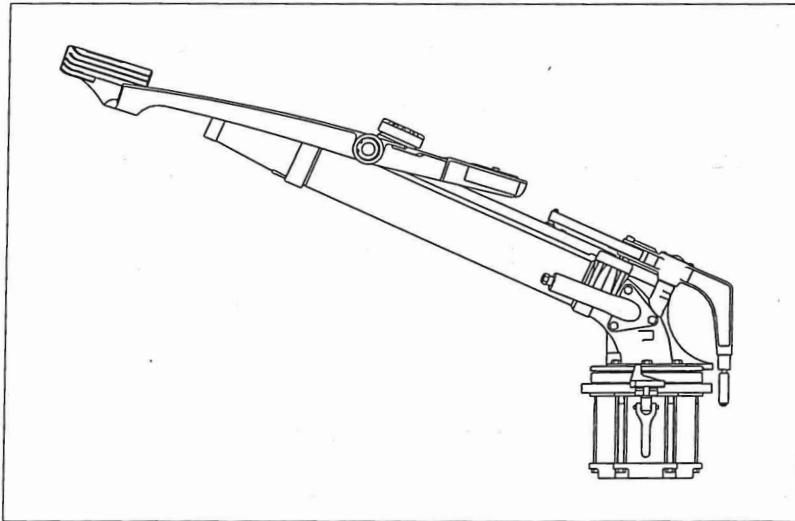

ASSEMBLY NUMBER
 9135-021 for 21°
 9135-024 for 24°
 9135-027 for 27°

part number	description	qty.
6010	Screw, 5/16-18 x 3/4"	3
6089	Plug, 3RN	1
6201	Plug, 7RN	1
7240	7V Vane	1
8311	Screw, #8-32 x .375"	
	Self-Tapping Pan Head	4
8328	Label, Warning — English, Spanish	1
8329	Label, Warning — German, Swedish	1
9118	Shaft, Trip Lever — SR200	1
9128	Gasket, Elbow — SR200	1
9134	Stop Bracket — SR200	1
9140	Gasket, Secondary Elbow — SR200	1
9143	Pin, Type E Grooved, .125 x .875"	1
9164	Elbow, Secondary — SR200	1
9136-021	Tube & Elbow Assembly, 21° — SR200	1
9136-024	Tube & Elbow Assembly, 24° — SR200	1
9136-027	Tube & Elbow Assembly, 27° — SR200	1



SR200 BIG GUN® PARTS LIST

8/01

9137 SHIFT LEVER ASSEMBLY, SR200

part number	description	qty.
6064	Nut, 5/16-18	1
6580	Insert, Rest Pad	2
7029	Washer, 5/16" Spring Lock	1
8139	Bumper	1
8197	Pin, Shift — SR100	1
9025	Lever, Shift — SR200	1
9123	Spacer, Shift Lever — SR200	1
9124	Bearing, Ball	2
9139	Seal, Shift Lever — SR200	1

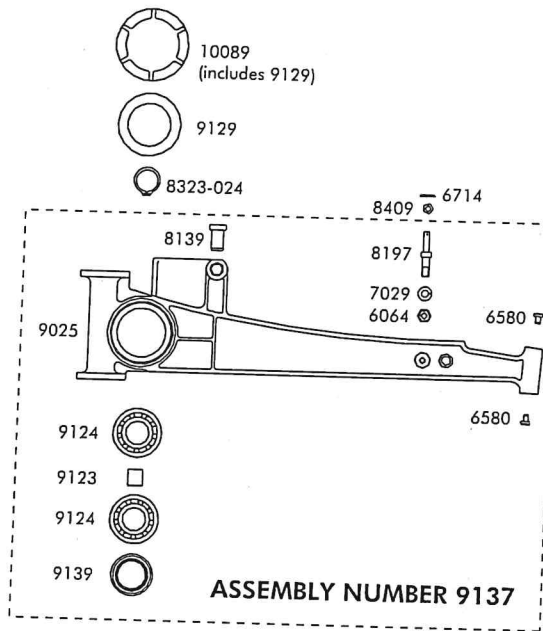

9122 TRIP LEVER ASSEMBLY, SR200

part number	description	qty.
6598	Bearing, Ball	2
6714	Pin, Cotter, .062 x .50"	1
8193	Pin, Stop — SR100	1
8282	Follower, Trip Spring — SR100	1
8320	Pin, Coiled Spring, .094 x .50"	1
8327	Spacer, Trip Lever — SR200	1
8966	Washer, Trip Lever — SR150	1
9024	Lever, Trip — SR200	1
9117	Seal, Trip Lever — SR200	1
9119	Shaft, Roller — SR200	1
9120	Roller, Trip — SR200	1
9121	Washer, Roller — SR200	1
9143	Pin, Type E Grooved, .125 x .875"	1

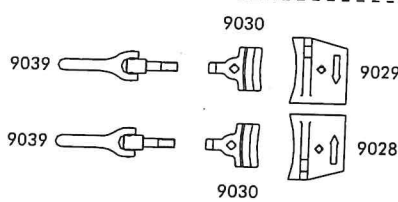
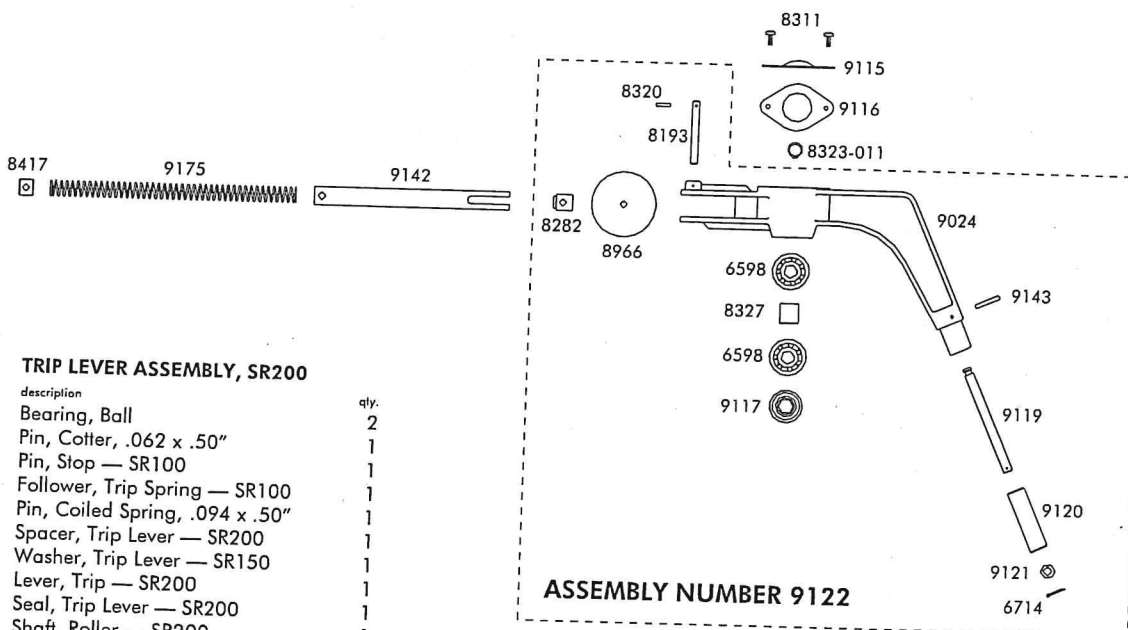



SR200 BIG GUN® PARTS LIST

8/01

9133 COUNTERWEIGHT ASSEMBLY, SR200		
part number	description	qty.
6048	Seal	2
6054	Bearing, Ball	1
9132	Counterweight — SR200	1

9138 DRIVE ARM ASSEMBLY, SR200		
part number	description	qty.
6045-001	Ring, Retaining, -156 Basic Int., Phos. Coated	1
6048	Seal	2
6054	Bearing, Ball	2
6580	Insert, Rest Pad	1
8139	Bumper	1
9141	Arm, Drive — SR200	1

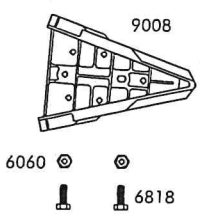
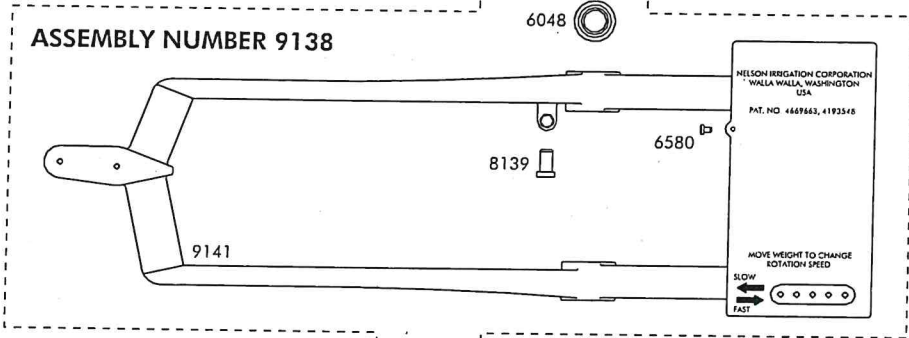
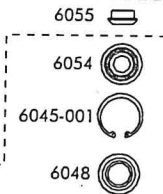
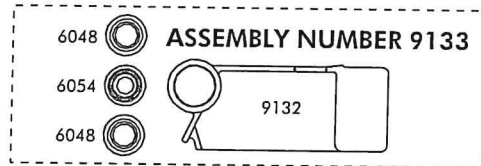
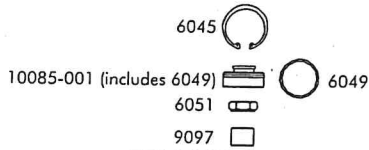

FINAL ASSEMBLY COMPONENTS, SR200		
part number	description	qty.
6045	Ring, Retaining, -156 Basic Internal	2
6049	O-Ring, -028	2
6051	Nut, .625-18 Special	2
6055	Spacer — CWT to Brkt — F200	1
6060	Nut, .25-20	2
6714	Pin, Cotter, .062 x .50"	1
6818	Screw, .25-20 x .75" Hex Head Cap	3
8311	Screw, #8-32 x .375", Self-Tapping Pan Head	2
8323-011	Ring, Retaining, -46 Basic Ext, Phos. Coated	1
8323-024	Ring, Retaining, -98 Basic External	1
8409	Washer, Trip Roller — SR100	1
8417	Stop, Trip Spring — SR100	1
8904	Washer, .25" Spring Lock	1
9008	Vane, Drive — SR200	1
9028	Stop, Clockwise — SR200	1
9029	Stop, Counterclockwise — SR200	1
9030	Clamp — SR200	2
9039	Flex-Handle Assembly	2
9097	Spacer, Drive Arm to CWT — SR200	1
9104	Weight, Arm — SR200	1
9115	Cap, Trip Lever — SR200	1
9116	Gasket, Trip Lever Cap — SR200	1
9129	Gasket, Shift Lever Cap — SR200	1
9131	Shaft, Drive Arm — SR200	1
9142	Guide, Spring — SR200	1
9175	Spring, Trip — SR200	1
9440	Spacer, Drive Arm to Shift Arm — SR200	1
10085-001	Cap Assembly, Arm Bearing — SR200	2
10089	Cap Assembly, Shift Lever — SR200	1

Bill Item no: 3-16

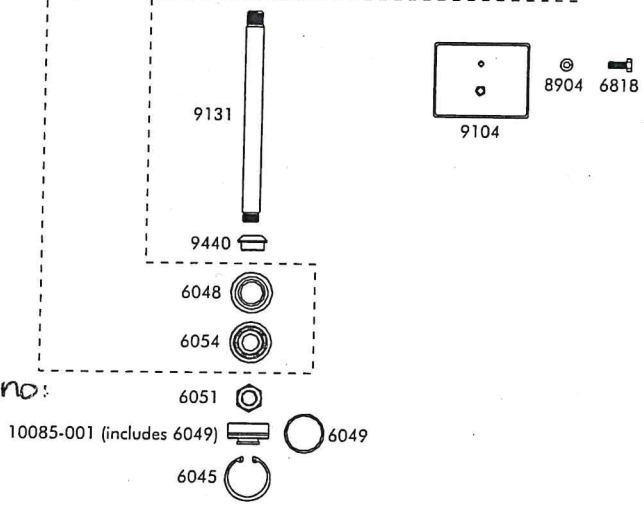



SR200 BIG GUN® PARTS LIST

8/01

BEARING ASSEMBLY HD200

part number	description	qty.
6345	Screw, 3/8-16 x 1"	6
	Hex Head Cap	1
9009	Brake — HD200	1
9010	Seal, Upper — HD200	1
9011	Seal, Lower — HD200	1
9019	Cover — HD200	1
9021	Housing — HD200	1
9108	Seal, Dust — HD200	2
9109	Bearing, Ball	2
9110	Gasket, Housing — HD200	1
9111	O-Ring, -347 Special	1
9112	O-Ring, -340	1
9113	Screw, 3/8-16 x 5 1/2"	6
	Hex Head Cap	1
9128	Gasket, Elbow — SR200	12
9172	Spring, Brake, Inner — HD200	12
9173	Spring, Brake, Outer — HD200	12
9276	Stem Assembly w/ Dust Seal — HD200	1
10084	Retainer Assembly — HD200	1
10090	Metric Flange Assembly — HD200	1
10091	Nelson Flange Assembly — HD200	1
10153-002	Screw, .375-16 x 6"	6
	Hex Socket Head Cap	1
10333-001	ANSI Flange Assembly — HD200	1

MOUNTING HARDWARE

part number	description	qty.
6345	Screw, 3/8-16 x 1" Hex Head Cap	6
9004	Screw, M8 x 1.25 x 25mm Hex Head Cap	6
9005	Gasket, Metric Flange — HD200	1
9130	Gasket, Flange — HD150	1

FLANGE GASKET AND FASTENERS FOR GUN MOUNTING

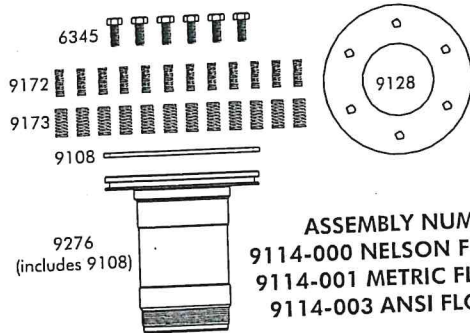
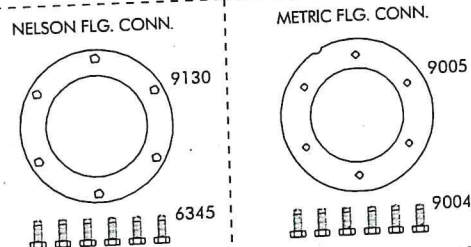

ASSEMBLY NUMBERS
 9114-000 NELSON FLG. CONN.
 9114-001 METRIC FLG. CONN.
 9114-003 ANSI FLG. CONN.

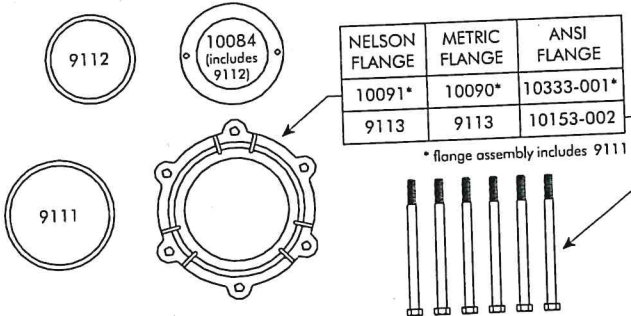
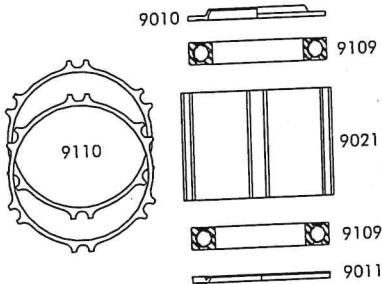
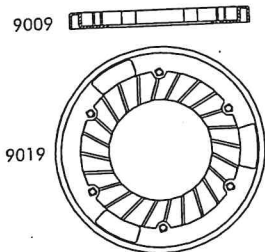

NELSON FLANGE	METRIC FLANGE	ANSI FLANGE
10091*	10090*	10333-001*
9113	9113	10153-002

* flange assembly includes 9111

WARRANTY AND DISCLAIMER

Nelson Big Gun® sprinklers are warranted for one year from date of original sale to be free of defective materials and workmanship when used within the working specifications for which the product was designed and under normal use and service. The manufacturer assumes no responsibility for installation, is limited solely to replacement or repair of defective parts, and the manufacturer will not be liable for any other or other consequential damages resulting from any defects or breach of warranty. THIS WARRANTY IS EXPRESSLY IN LIEU OF ALL OTHER WARRANTIES, EXPRESS OR IMPLIED, INCLUDING THE WARRANTIES OF MERCHANTABILITY AND FITNESS FOR PARTICULAR PURPOSES AND OF ALL OTHER OBLIGATIONS OR LIABILITIES OF MANUFACTURER. No agent, employee or representative of the manufacturer has authority to waive, alter or add to the provision of the warranty, nor to make any representations or warranty not contained herein.